

Low-Cost Multifunction Boards

PCI-20428W Series

ISA AND EISA Bus

TYPICAL APPLICATIONS

- General-Purpose Data Acquisition, Test, Measurement, and Control
- OEM Applications
- Waveform Generation
- Transient Capture

KEY FEATURES/BENEFITS

- Premium Functionality with Ultra-low Cost
- 16SE/8Diff Analog Inputs with DMA Data Transfer to Host Memory
- Two Rate Generators with 8MHz Crystal Timebase
- Software Programmable Gains of 1, 10 100 or 1, 2, 4 8
- 12-Bit Resolution (1 Part in 4096)
- Two 12-Bit Analog Outputs with DMA Transfer from Host Memory
- 100Khz Multichannel Analog I/O Throughput
- 8 Digital Inputs, 8 Digital Outputs
- One 16-bit Counter
- Master Link C/C++ DOS Drivers and Windows DLL Included
- Supported by Visual Designer™ Application Generator
- Lifetime Warranty

DESCRIPTION

The PCI-20428W Series Low-Cost Multifunction Boards are ideal for general-purpose data acquisition, test, measurement and control applications. The boards include all the basics — analog inputs and outputs, digital inputs and outputs, and a counter/timer. They also include premium DMA features not normally found in low-cost boards. Including:

- Triggered DMA capability for transient capture at up to 100kHz.
- Analog output DMA capability for waveform generation at up to 100,000 samples per second.
- Concurrent analog input and analog output DMA for stimulus/response applications.

DOS Drivers, Windows DLL, and our SYSCHECK diagnostic software are included with the board. Visual Designer, our powerful application generator software, is fully supported and available separately.

ANALOG I/O —The PCI-20428W-1 and PCI-20428W-2 Boards can be configured for 16 single-ended, or for 8 differential analog input channels through jumper settings on the board. The PCI-20428W-3 offers 16 single-ended channels only. The PCI-20428W-1 and PCI-20428W-2 include a software programmable gain instrumentation amplifier to extend their measurement range. The PCI-20428W-1 offers gains of 1, 10, and 100; while the PCI-20428W-2 offers gains of 1, 2, 4, and 8. The PCI-20428W-3 has unity gain only. All versions offer jumper programmable A/D full-scale ranges of 0-5V, 0-10V, $\pm 5V$ and $\pm 10V$. All analog inputs are protected to $\pm 35V$ with power applied to the board, and $\pm 20V$ with no power.

The PCI-20428W-1 and PCI-20428W-2 Boards are equipped with two analog output channels. They provide voltage outputs at 12-bit resolution. Available output ranges are 0-10V, $\pm 5V$, and $\pm 10V$, which are all jumper selected.

Analog data can be acquired and/or generated under program, DMA or interrupt control. Input and output can be performed separately or in synchronization.

Programmed I/O — This method is used for lower-speed applications, or for applications where an accurate timebase is not required.

DMA Analog I/O — This method is used for high-speed applications, waveform generation applications, applications which must run in the background, and applications which require an accurate timebase. For analog input, the channels are scanned sequentially from channel 0 to channel N at a single gain. With this method, data is automatically transferred by the PC's direct memory access (DMA) controller. Conversions are started by either the on-board analog pacer clock, or by an external digital pulse. The entire DMA analog process can be started either by a software command, or upon the occurrence of an external digital trigger signal.

Interrupt-Driven I/O — This method can be used for moderate-speed applications, or applications which need to run in the background. A conversion is started by software, by a timing pulse from the on-board analog pacer, or by an external digital signal. When the conversion is complete, an interrupt is generated, and the interrupt routine reads or writes the data. This mode is not supported by the drivers, but can be programmed at the register level.

DIGITAL I/O — The PCI-20428W Series Boards have eight TTL compatible digital inputs and eight TTL compatible buffered digital outputs. All are protected from damage under power off conditions with signals applied.

COUNTER — The board includes one 16-bit general-purpose counter channel with clock and gate inputs. The counter channel can perform general-purpose event counting on TTL level signals at frequencies up to 8MHz. If the counter channel is not used for general-purpose counting operations, it can be programmed as a rate generator prescaler to achieve very low sample rates for the analog input and outputs.

RATE GENERATORS — Two 16-bit rate generators are provided, one to pace analog inputs, and one for analog outputs. The timebase for both rate generators is derived from an on-board 8MHz crystal oscillator. Rates from 120Hz to 4Mhz can be programmed. The general-purpose counter channel can optionally be used as a 16-bit prescaler to both rate generators, extending the range of possible sample rates from 0.0018Hz to 2MHz.

SOFTWARE

Intelligent Instrumentation offers a complete range of software tools that you can use with the PCI-20428W Series Boards. You can select the software which best meets your needs based on your application requirements, the amount of time you have available, your level of programming expertise, and your budget.

Drivers for C language under DOS are included with the board. Also included is our DLL for Windows 3.1 or higher. If PASCAL or BASIC drivers for DOS are desired, the Master Link Libraries for DOS and Windows can be purchased separately. See the following Master Link Software Libraries summary. Complete documentation covering the use of these drivers with the PCI-20428W boards is included in the user manual.

APPLICATION GENERATOR SOFTWARE

Visual Designer (PCI-20901S) — Visual Designer is a powerful, easy to use application generator that allows you to develop custom data acquisition and control applications for Windows — without programming. Using the graphical block diagram development environment, you can combine professional screen displays and user interface elements with powerful data acquisition and processing blocks to create a custom instrument or control panel in a fraction of the time it takes using a programming language.

SOFTWARE LIBRARIES & DRIVERS

Master Link Software Libraries for DOS and Windows (PCI-20369S-1) — The Master Link Software Libraries are available for customers who need to develop custom applications using a programming language. The Master Link libraries support popular programming languages, such as C, Turbo-PASCAL, and Visual BASIC.

Quinn-Curtis Graphics Libraries (PCI-20397S, PCI-20398S, PCI-20399S Series) — The Quinn-Curtis software libraries simplify your program development and ensure that your final applications are easy-to-use and have high-quality graphical displays. You can use these libraries in conjunction with the drivers which are included with the board, or with our PCI-20369S-1 Master Link Software Libraries for DOS and Windows. The Quinn-Curtis Graphics Libraries include Science and Engineering Tools (PCI-20397S Series), Real-Time Graphics and Measurement and Control Tools (PCI-20398S Series), and Windows Charting Tools (PCI-20399S-1).

SYSCHECK PC — We ship each of our data acquisition boards with our innovative SYSCHECK PC software, an easy-to-use system assurance and diagnostics package. You can use SYSCHECK to quickly verify whether or not your Intelligent Instrumentation hardware is installed properly and working correctly.

SIGNAL CONDITIONING & TERMINATION PRODUCTS

Access to all the analog and digital signals on the PCI-20428W Series boards is through a single standard density 50-pin ribbon cable connector at the bulkhead.

Low-Cost Termination Panel (PCI-20429T-1) — The PCI-20429T-1 plugs directly into the back of the PCI-20428W Series Boards. This low-cost termination panel gives you access to all of the analog and digital inputs and outputs provided by the PCI-20428W Series boards, including 16 single-ended or 8 differential analog inputs, 2 analog outputs, 8 digital inputs and 8 digital outputs. Provisions are made to secure the panel to the rear of the computer.

Termination Panel Adapter (PCI-20430A-1) — This termination panel adapter plugs directly into the back of the PCI-20428W Series Boards, with provisions to secure to the rear panel. If you need analog or digital isolation, or have special signal conditioning requirements, the PCI-20430A-1 can be used to adapt the PCI-20428W Series Boards to our complete line of 3U Eurocard size analog and digital termination panels and cables. The PCI-20430A-1 adapts the following products for use with the PCI-20428W Series Boards.

FOR ANALOG SIGNALS:

PCI-20303T Series 3U Analog I/O Panels — The PCI-20303T-1 supports 16 single-ended or 8 differential analog inputs and 2 analog outputs. The PCI-20303T-2 features cold-junction compensation (CJC) circuitry to support thermocouple inputs. When the CJC function is activated, the panel supports 7 differential analog inputs, 1 CJC, and 2 analog outputs. Both panels have standard-density connectors. Use PCI-20310A-1 analog cable to connect the termination panels to the PCI-20430A-1 adapter.

PCI-20353T-1 & PCI-20354T-1 3U Analog I/O 5B Panels — The PCI-20353T-1 supports our industry standard PCI-5B Series of high-performance signal conditioning blocks. These blocks interface to a variety of signal sources to provide isolated channels of analog input or output. The PCI-20353T-1 termination panel provides eight analog I/O channels; you can expand the channel capacity to 16 by adding the PCI-20354T-1 Expander Panel as well. Use PCI-20310A-1 analog cable to connect the PCI-20353T-1 termination panel to the PCI-20430A-1 adapter. Refer to the Isolated Analog Signal Conditioning Blocks product data sheet for information on the PCI-5B Series blocks.

FOR DIGITAL SIGNALS:

PCI-20305T-1 3U Digital I/O Panel — The standard-density PCI-20305T-1 panel provides 16 terminals/signal conditioning spaces. These can either be configured as 8 digital inputs and 8 digital outputs, or as 8 channels for handshaking, counter, burst generator, and external interrupt functions. Use PCI-20311A-1 digital cable to connect the PCI-20305T-1 to the PCI-20430A-1 adapter.

PCI-20324T & PCI-20326T 3U Optically-Isolated Digital I/O Panels — These panels are used in conjunction with the PCI-1107 through -1112 Series of slim-line Digital Opto-Isolator blocks. The

blocks, which sense voltage levels and control load switching, plug directly onto the panels. The PCI-20324T-1 has a standard-density connector and provides eight digital input channels when used with the PCI-20428W boards. You can add 8 digital output channels using the PCI-20326T-1 Expander Panel, which can be interfaced to the base panel with an inter-board connector cable. Quick-disconnect versions of these panels are also available (PCI-20324T-2 and PCI-20326T-2). These panels feature pluggable screw terminals which greatly reduce wiring and assembly time. Use PCI-20311A-1 digital cable to interface the PCI-20324T panels to the PCI-20430A-1 adapter.

PCI-20355T 3U Digital-Relay Output Panels — The PCI-20355T-1 termination panel accommodates plug-in DIP relays to switch a connected load. When used with the PCI-20428W boards, the panel provides 8 channels of relay output. Kits of 16 normally open (NO) reed relays (PCI-20359A-1) or normally closed (NC) reed relays (PCI-20360A-1) are available for the panels and must be purchased and installed separately. The PCI-20355T-2 is a quick-disconnect version of this panel. It features pluggable screw terminals which greatly reduce wiring and assembly time. Use PCI-20311A-1 digital cable to connect the PCI-20355T panels to the PCI-20430A-1 adapter.

PCI-20361T 3U Digital-Isolated Input Panels — The PCI-20361T-1 standard-density termination panel provides both digital signal conditioning and isolation through opto-couplers built into each channel. When used with the PCI-20428W boards, the panel supports 8 digital inputs at the lowest possible cost per channel. The PCI-20361T-2 is a quick-disconnect version of this panel. It features pluggable screw terminals which greatly reduce wiring and assembly time. Use PCI-20311A-1 digital cable to connect the PCI-20361T panels to the PCI-20430A-1 adapter.

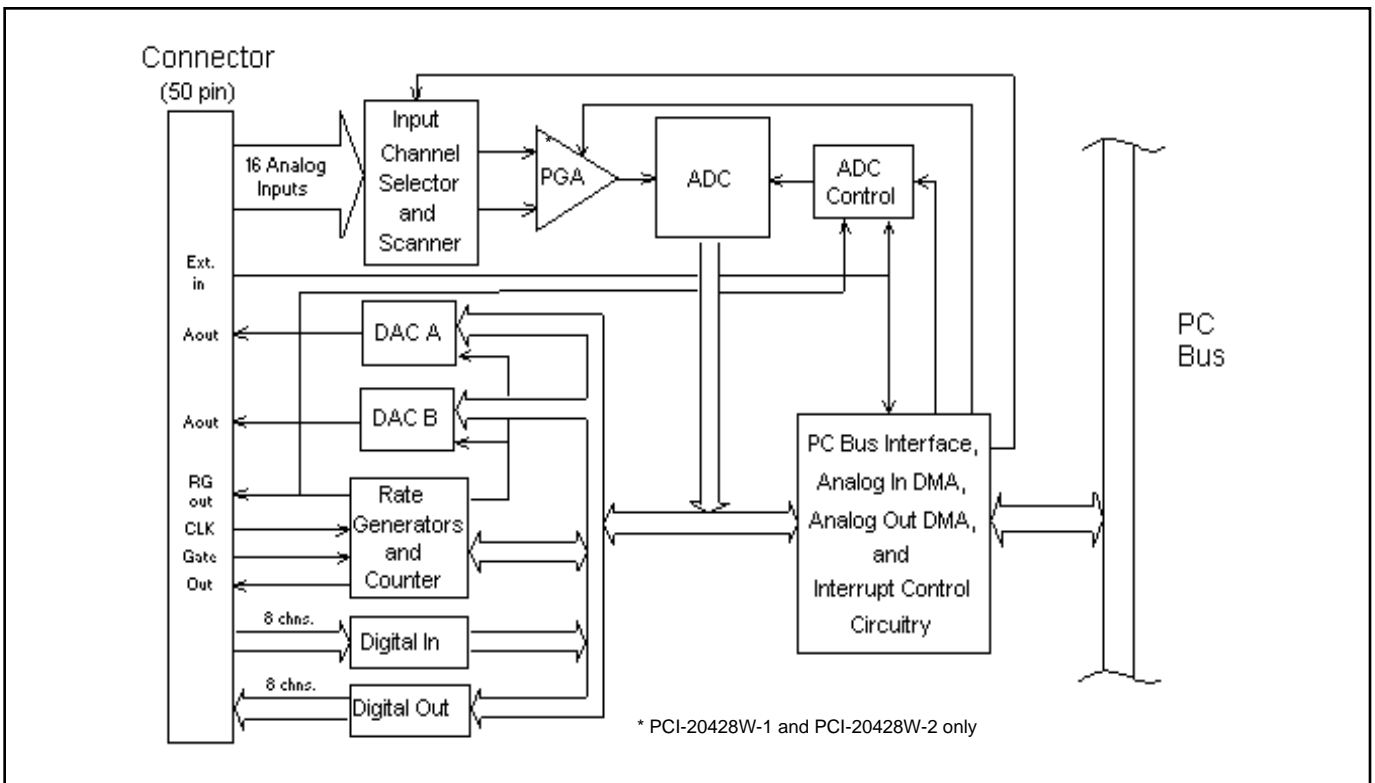

PCI-20428W Series block diagram.

SPECIFICATIONS — PCI-20428W SERIES

All specifications are typical at 25°C unless otherwise noted.

PARAMETERS	CONDITIONS	SPECIFICATION
Bus Compatibility		PC/XT/AT/EISA
Analog Input		
Number of Channels PCI-20428W-1, -2	Single-ended Differential	16 8
Resolution		12 bits (1 part in 4096)
Voltage Ranges PCI-20428W-1, -2, -3	Gain = 1	0-5V, 0-10V, ±5V ±10V
PCI-20428W-1	Gain = 10	0-0.5V, 0-1V, ±0.5V, ±1V
PCI-20428W-1	Gain = 100	0-0.05V, 0-0.1V, ±0.05V, ±0.1V
PCI-20428W-2	Gain = 2	0-2.5V, 0-5V, ±2.5V, ±5V
PCI-20428W-2	Gain = 4	0-1.25V, 0-2.5V, ±1.25V, ±2.5V
PCI-20428W-2	Gain = 8	0-0.625V, 0-1.25V, ±0.625V, ±1.25V
Over Voltage Protection	Power on/Power off	±35V / ±20V
Gain Accuracy	Gain ≤10 Gain = 100 RTO	0.05% 0.08% ±2.44mV
Offset Voltage		500pA
Bias Current		10 ⁹ ohms/ 10pF
Input Impedance		
Common Mode Range Rejection	V _{cm} = V _{range} - (V _{diff} * Gain)/2 60Hz, 100 ohm imbalance Gain ≤10 Gain = 100	±10V (DC + Peak AC) min -80dB (0.02LSB/V) -92dB (0.05LSB/V)
Noise	Input grounded at connector; RMS/P-P Gain ≤10 Gain = 100	0.5 LSB/1LSB 1.0LSB/3LSB
Monotonicity	No missing codes	12 bits
Linearity Error		±0.012%FS, ±1/2 LSB
Analog Outputs		
Number of Channels-PCI-20428W-1, -2		2
Resolution		12 bits (1 part in 4096)
Voltage Ranges		0-10V, ±5V, ±10V
Digital I/O		
Number of Ports	8 Channels (bits) each	2 (1 input, 1 output)
Input Levels		TTL compatible (Schmitt Trigger)
Input Current, High Level/Low Level		20µA/20µA
Output Levels		TTL compatible
Source/Sink Current	V _{out} = High/Low	400µA/8mA
Counters		
Number of Channels		1
Clock Speed		8MHz
Input Levels		TTL compatible (Schmitt Trigger)
Output Levels		TTL compatible
Source/Sink Current	V _{out} = High/Low	15mA/64mA
Timebase Generator		
Type	Crystal-based	Rate Generator
Number		2 (1 analog input, 1 analog output)
Resolution		125nsec
Output Frequency Range		122Hz to 4MHz
16-bit		0.002Hz to 2MHz
With Prescaler		TTL compatible (Schmitt Trigger)
Input Levels		TTL compatible
Output Levels		15mA/64mA
Source/Sink Current	V _{out} = High/Low	
Interrupts		
Sources		EOC, AI Rate Generator, AO Rate Generator
PC Levels		IRQ2, IRQ3, IRQ5
System Throughput		
Multi-Channel Analog Input/Output Under DMA		100kHz
DMA Channels		
Number	Jumper Selected	2 (1 input, 1 output)
PC Levels		DMA1, DMA3
Modes		Triggered/Non-Triggered, Linear/Circular Buffer
Input		Linear/Circular Buffer
Output		
Physical Characteristics		
Power Requirements +5V		1A
Size	Length x Height	8.0" x 4.2" (20.3cm x 10.7cm)
Operating Temperature Range		0-70°C

The information provided herein is believed to be reliable; however, INTELLIGENT INSTRUMENTATION assumes no responsibility for inaccuracies or omissions. INTELLIGENT INSTRUMENTATION assumes no responsibility for the use of this information, and all use of such information shall be entirely at the user's own risk. Prices and specifications are subject to change without notice. No patent rights or licenses to any of the circuits described herein are implied or granted to any third party. INTELLIGENT INSTRUMENTATION does not authorize or warrant any INTELLIGENT INSTRUMENTATION product for use in life support or aircraft control applications.

Visual Designer is a trademark of Intelligent Instrumentation.