

Low Cost | High Performance



## Features

- 16 Single-Ended or 8 Differential A/D Channels
- 14 bit Analog Resolution
- 100kHz A/D Sampling Rate
- ±2.5, ±5, ±10V Voltage Range
- 4x 14 bit D/A Channels (PCI-730)
- 24 (3x 8) DIO Channels (PCI-730/726)
- 3x 16 bit Counter/Timers (User) (PCI-730/726)
- 3 Interrupt Sources (PCI-730/726)
- 2048 FIFO buffer with programmable word count
- DB25M (A/D & D/A); IDC40 (DIO) Connectors
- Windows98/ME/2000/XP OS Support (NT on request)
- Linux OS Support
- WaveView for Windows Data Acquisition & Logging Software
- Labview, Testpoint and VEE Pro Drivers

## Description

The **PCI-730**, **PCI-726** and **PCI-725** are low cost yet high performance data acquisition boards for the PCI-bus. They are multi-function I/O boards which feature both analog and digital I/O on the same board. Designed with university students in mind, the boards feature industry standard low cost connectors. This makes for easy connectivity, as the user does not have to purchase expensive SCSI cables or connectors.

Extremely compact, the PCI-730/726/725 features 16 single-ended or 8 differential 14-bit analog input channels with an overall sampling speed of 100KHz. Compared to other data acquisition boards, our board features four 14-bit analog output channels instead of the industry standard two. These are ideal for laboratory use as voltage references.

Typical applications include analog input streaming, voltage measurements, voltage reference outputs, analog and digital data logging, digital I/O for control of relays, frequency counter for event logging and much more.

Included with the PCI-730/726/725 is our free data acquisition package, WaveView for Windows which allows the user to start sampling as soon as the card is plugged in.

**DB-25M**

CH1	14	1	CH0
CH3	15	2	CH2
CH5	16	3	CH4
CH7	17	4	CH6
CH9	18	5	CH8
CH11	19	6	CH10
CH13	20	7	CH12
CH15	21	8	CH14
DAC0	22	9	AGND
DAC2	23	10	DAC1
+VDD	24	11	DAC3
EXT_TRIGGER	25	12	-VDD
		13	NOT USED

**IDC-40M**

PA0	1	2	PA3
PA2	3	4	PA5
PA4	5	6	PA7
PA6	7	8	PA9
PB0	9	10	PB1
PB2	11	12	PB3
PB4	13	14	PB5
PB6	15	16	PB7
PC0	17	18	PC1
PC2	19	20	PC3
PC4	21	22	PC5
PC6	23	24	PC7
DGND	25	26	NOT USED
CLK0	27	28	NOT USED
COUT0	29	30	GATE0
GATE1	31	32	CLK1
CLK2	33	34	COUT1
COUT2	35	36	GATE2
+5V	37	38	DGND
DGND	39	40	DGND

## Specifications

<b>ANALOG INPUTS (A/D)</b>	
<b>Input Characteristics</b>	
Input Channels:	16 SE or 8 Differential
Input Ranges:	±2.5V, ±5V, ±10V
Maximum Working Voltage:	±11V relative to module ground
Resolution:	14-bit (1 in 16384)
Input Coupling:	DC
<b>A/D Conversion Characteristics</b>	
Max sampling rate:	250KHz (for a single channel)
Relative Accuracy:	±2 LSB maximum
A/D FIFO buffer size:	2048 samples
Acquisition Modes:	Triggered Interrupt
Input Impedance:	1M Ohm
System Noise:	1 LSB
<b>ANALOG OUTPUT (D/A)</b>	
No of Channels:	4x 14-bit
Output Ranges:	±10V
Full Scale Error:	±2 LSB
Settling Time:	1mS to 0.1% of full scale 2mS to 0.015% of full scale
Output Drive:	±10V @ 5mA
Power On State:	0V
<b>DIGITAL I/O (DIO)</b>	
No of TTL I/O lines:	24
Logic Levels:	Input Low Voltage: -0.5V to 0.8V Input High Voltage: 2.0V to 5.0V Output High Voltage Min: 2.4V Output Low Voltage Max: 0.45V Maximum Output Current: 2mA
<b>DIGITAL TRIGGER</b>	
Trigger Source:	External Trigger
Compatibility:	TTL
Pulse Width:	100nS
<b>COUNTER/TIMERS</b>	
Number of Counters:	3 (16-bit resolution) (82C54/TTL)
Clock Source: Jumper Selectable	Scaled Internal up to 8MHz (External)
Gate Source: Jumper Selectable	Software Controlled (External)
<b>External Interface</b>	
Connector Types:	DB25M (A/D & D/A), IDC40 (DIO & C/T)
<b>PCI Interface</b>	
Compliant:	PCI 2.2 Master & Slave 3.3V or 5.0V compatible with auto-detect Auto selected
<b>Environmental / Physical</b>	
Dimensions:	142 x 98,5mm
Rel. Humidity:	0% to 90% (non-condensing)
Operating Temp:	0°C to 70°C
Power Requirements	+5V @ 1.2A typ



Supplied with Internal Cable for Digital I/O (IDC40 to DB37)

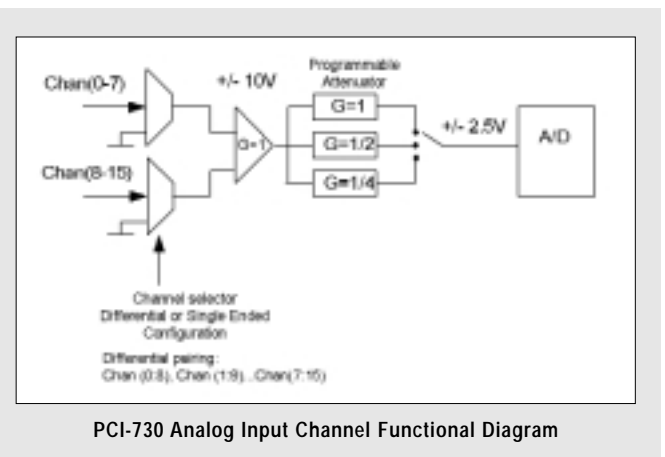

## Ordering Information

Supplied with EDR Enhanced Software and Internal Cable with PC bracket (IDC40 to DB37)

PCI-730	100kHz 16 Channel 14-bit A/D, 24 DIO, Counters & 4x 14-bit DACs
PCI-726	100kHz 16 Channel 14-bit A/D, 24 DIO & Counters
PCI-725	100kHz 16 Channel 14-bit A/D

## Optional Accessories

<b>OPTION 1:</b>	
<b>ADPT-2526</b>	DB25 (F) & IDC26 (M) to 27way Screw Terminal Adaptor
<b>DB25M/F</b>	DB25 (M) to DB25 (F) Screened Cable

<b>OPTION 2:</b>	
<b>ADPT-3740</b>	DB37 (M) & IDC40 (M) to 41way Screw Terminal Adaptor
<b>DB37F/F</b>	DB37 (F) to DB37 (F) Screened Cable

## Optional Accessories Diagram

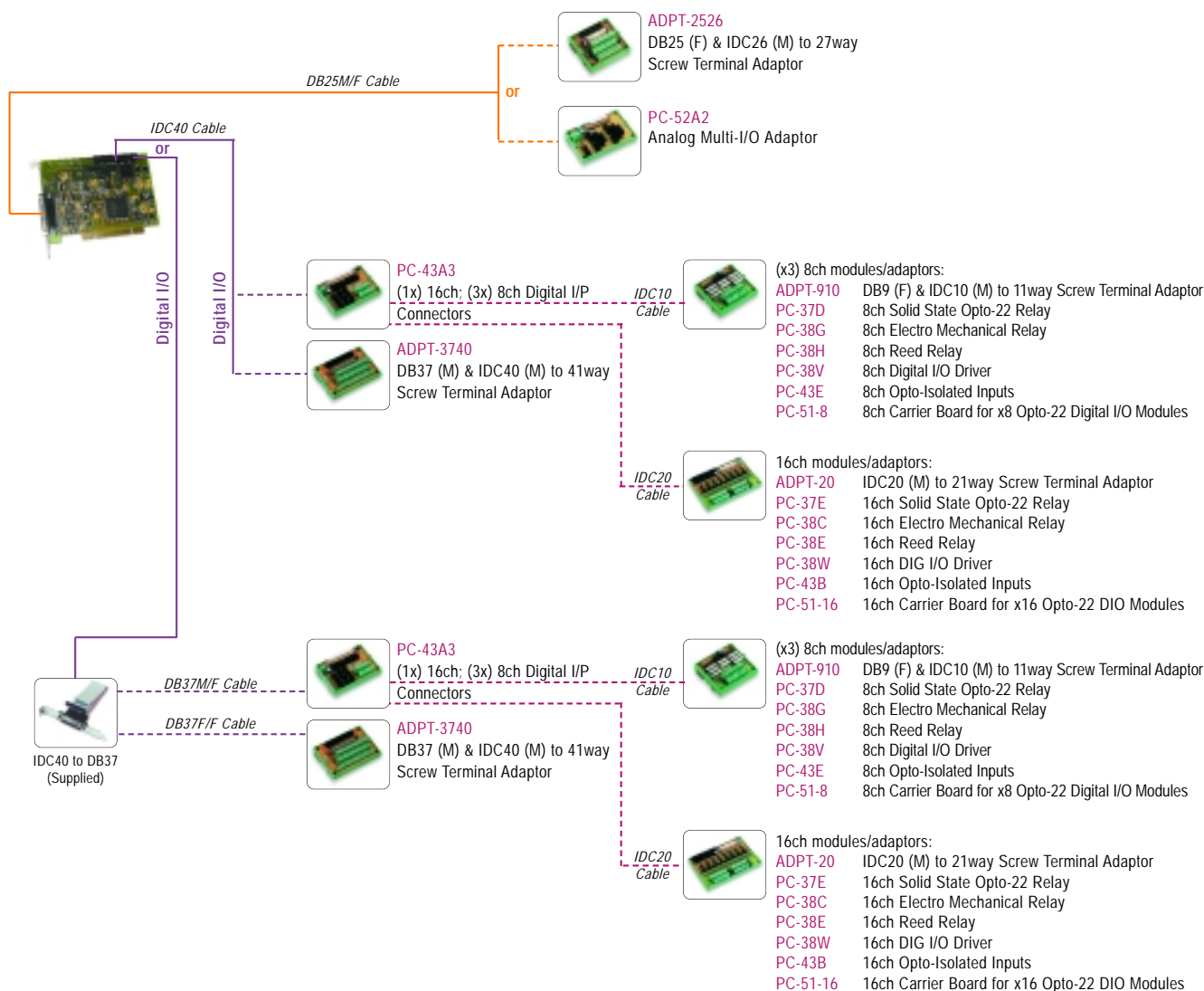

## FREE WaveView for Windows Software



**WaveView for Windows** is a new Microsoft® Windows™ based data acquisition package supporting our PCI range of personal computer plug-in cards. The software is extensively configurable and easy to use.

The **WaveView for Windows** software package is used for collecting and analyzing data. Two modes of operation are supported, **scope mode and chart recording**. WaveView can also be used as a **waveform generation tool, or a digital power supply controller**. The software is extensively configurable, easy to use and quick to learn.