

# UEISIM™

## Simulink® and RTW Linux based I/O Target

- Simulink applications, compiled RTW run standalone on the I/O cube.
- Powerful, compact and rugged
- Flexible: Over 30 I/O boards available including A/D, D/A, Digital I/O, Counter/Timer, Quadrature encoder, Serial, CAN and ARINC 429 communications.
- Standard Linux OS (2.6.x Kernel)
- Standard Ethernet 100BaseT Interface
- Small footprint
  - 4" x 4.1" x 4" provides 3 I/O slots (UEISIM 300)
  - 4" x 4.1" x 5.8" provides 6 I/O slots (UEISIM 600)
- Supports up to 5k "loops" per second
- Ideal for HIL (Hardware-in-the-loop) applications
- Ideal for development, prototype and production



UEISIM 300 shown



The UEISIM is available in two different sizes. The UEISIM 300 shown above allows the installation of up to 3 I/O boards. The UEISIM 600 is 1.8" taller and allows the installation of up to 6 I/O boards. For larger applications, the Cubes are easily daisy-chained with up to 64 cubes allowed on a single network.

## General Description:

The UEISIM offers Simulink users a new, powerful and flexible I/O target. Models built in Simulink are deployed directly on the UEISIM using Real-Time Workshop. The combination creates a powerful new solution in the creation and tuning of many real-time and non-real-time applications. These include simulation model verification, rapid prototyping, and hardware-in-the-loop testing. The UEISIM is rugged, flexible and expandable enough that it is not only a great solution while in your development cycle, it's also the ideal solution for your production hardware.

To use the UEISIM, simply: a) Build your Simulink application. b) Open MATLAB and select Simulink/Embedded target for UEISIM. c) Convert your model to use the UEISIM I/O blocks (if you had not used them in your original model). d) Create an executable via RTW e) Connect the UEISIM in "external mode" (if you wish to remotely monitor the application while running on the UEISIM). f) Start your simulation. Six easy steps and your simulation is running live on real hardware.

The UEISIM 300 is 4" x 4" x 4" and offers 3 I/O slots. The UEISIM 600 is slightly larger at 4" x 4" x 5.8" and provides 6 I/O slots and allows up to 150 analog inputs or 288 DIO channels. The UEISIM uses the same I/O boards as our popular PowerDNA family and includes analog input (with up to 24 bit resolution), analog output (up to 32 channels PER BOARD), digital I/O, Serial and CAN communications, ARINC-429 networking, counter/timer, quadrature encoder input and more. With over 30 different I/O boards available there is sure to be a configuration perfect for your application.

The heart of every UEISIM is a PowerPC processor running a standard (2.6.x) Linux OS kernel. Flash memory contains the OS Kernel and drivers for each of the I/O boards. The CPU/NIC also provides an SD Card slot, Ethernet interface (including a single port switch), Intercube trigger/sync interface, RS-232 serial port, power supply inputs and a variety of annunciator LEDs. The file system is contained on the SD card and includes the other components of the operating system such as libraries, utilities, init script and daemons.

The UEISIM is rugged and robust. Tested from -40° to +85° C, at 50 g shock, 5 g vibration and altitudes up to 70,000 feet, the UEISIM is tough enough for the most challenging applications. All I/O is also fully isolated from the controller, so the UEISIM is immune to the glitches and spikes so commonly seen in an industrial environment.

The UEISIM cubes offer a wide variety of mounting options. A flange kit is available that allows the cubes to be mounted to a wall or other flat surface. Rack kits and DIN Rail kits are available to allow mounting in 19" racks or on DIN rails, respectively. For portable applications there is even an attach style carrying case that will safely hold

a cube, its power supply, cables and screw terminal panels.

Whether your application requires a few I/O channels or a few thousand, the UEISIM is an ideal solution. The Cube's unique combination of clean and simple Simulink/RTW target compatible Linux operating system, I/O flexibility, compact size, mechanical and electrical ruggedness and ease of use is unparalleled.

## UEISim Hardware Block Diagram:

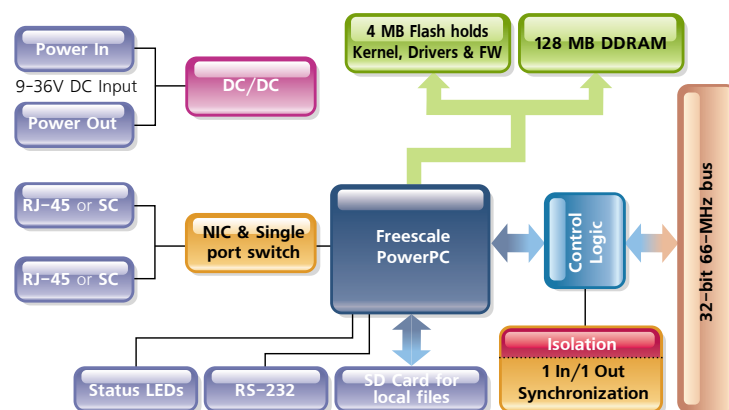

## UEISIM Cube Interface:

### A Network Connectors

Ethernet connection to a PC, another Cube or an external device; a second connector provides a single port switch for additional connectivity. You can select from models that provide RJ-45 jacks for copper cabling or SC-type jacks for 100BaseFX optical cable.

### B USB Port

USB Ver 1.1 port is not currently active.

### C SD Card Slot

Secure Digital (SD) Card slot for onboard data storage. It also stores both data and linux embedded programs deployed on the cube. Supports FAT12, FAT16 and FAT32 filesystems.

### D Serial Port

Using the supplied serial cable, you perform initial setup of the operating parameters from any serial terminal running at 57,600 baud/8 data bits/no parity/1 stop bit. From a terminal program you can, for instance, change the IP address from the default, if necessary. Your Linux program also has the capability to target the port as a standard serial port. You also download updated firmware through the serial port.

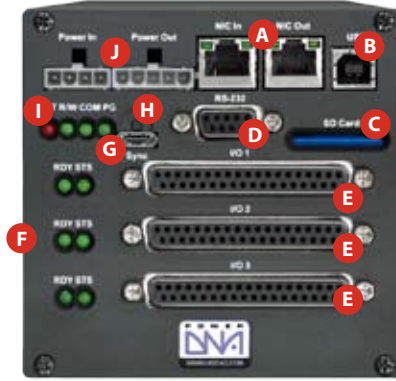

### E I/O Board Slots

Cubes provide either 3 or 6 I/O slots. Boards installed in the I/O slots provide the various analog, digital and communications functions required by your application. Signals may be connected directly to the I/O boards via your custom cabling or through our easy-to-use screw terminal panels. Boards ordered with your cube are factory installed. It is also a simple task to reconfigure cubes in the field.

### F I/O Layer Status LEDs

These two green lights give a visual indication of the status of each I/O layer.

### G Sync Connector

High-speed Cube-to-Cube synchronization connector.

### H Reset Button

Recessed to prevent accidental activation, this button resets the CPU layer for activities such as downloading and installing new firmware for the Cube.

### I Communication Status LEDs

These LEDs monitor communications through the serial and infrared ports.

**ATT** - Attention • **R/W** - Read/Write

**COM** - Communications underway

**PG** - Power Good / Ready

### J Power Connectors

Power-In, 9-36V DC either from the DNA-PSU-24 (included with the Cube), a user-supplied source, or daisy-chained from another UEIPAC Cube.

Power-Out (same voltage as applied to Power-In) to another Cube, if desired.

## Pinout Diagrams:

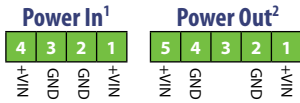

### Synchronization

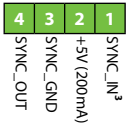

### Serial (RS-232)

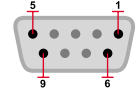

<sup>1</sup> Mating connector: Molex PN 39-01-4040

<sup>2</sup> Mating connector: Molex PN 39-01-4050

## Technical Specifications:

Software Requirements	
MATLAB	Version 2007b or greater
Simulink	Version 7.0 or greater
Real-Time Workshop	Version 7.0 or greater
Cube Operating System	
Embedded OS	Linux, kernel 2.6.x
Language	C
Development Environments	Simulink / RTW with Cygwin environment on a Windows PC
Standard Interfaces	
To Host Computer	10/100Base-T, standard RJ-45 connector
Daisy chain output	10/100Base-T, standard RJ-45 connector
Config/General	RS-232, 9-pin "D"
Sync	Allows synchronization of multiple cubes
Processor	
CPU	Freescale MPC5200, 400 MHz, 32-bit
Memory	128 MB (not including on-board Flash Memory which contains OS kernel, I/O drivers and firmware)
File Storage	SD Card (4GByte max, 2 GByte card included)
Status LEDs	Attention, Read/Write, Power, Communications Active

Performance	
Update rate	5 kHz typical
Environmental	
Electrical Isolation	350 Vrms
Temp (operating)	Tested to -40 °C to 85 °C
Temp (storage)	-40 °C to 100 °C
Humidity	0 to 95%, non-condensing
Vibration	
(IEC 60068-2-64)	10-500 Hz, 5 g (rms), Broad-band random
(IEC 60068-2-6)	10-500 Hz, 5 g, Sinusoidal
Shock	
(IEC 60068-2-27)	50 g, 3 ms half sine, 18 shocks at 6 orientations; 30 g, 11 ms half sine, 18 shocks at 6 orientations
Altitude	70,000 feet, maximum
Physical Dimensions	
UEIPAC 300	4.1" x 4.0" x 4.0" with 3 I/O slots
UEIPAC 600	4.1" x 4.0" x 5.8" with 6 I/O slots
Power Requirements	
Voltage	9 - 36 VDC (AC adaptor included)
Power Dissipation	4 W at 24 VDC (not including I/O boards)

## Ordering Guide:

Part Number	Description
<b>UEISIM Cubes (includes Mathworks Driver Software, Linux OS, Universal AC power supply, Serial/Ethernet cables)</b>	
UEISIM 300	Linux based Simulink/RTW I/O target with 3 available I/O slots
UEISIM 600	Linux based Simulink/RTW I/O target with 6 available I/O slot
<b>PowerDNA Cube Upgrade to UEISIM</b>	
UEISIM UPG	Upgrade any PowerPC PowerDNA Cube to the UEIPAC series