

WLP-6821-10

10" VIA C7 Fanless & Ultra Slim Panel PC



Features

- True Fanless Thermal Solution
- VIA C7 1.0G (standard, up to 1.6G) CPU
- IP65 / NEMA4 Water / Dust Proof on Front & Rear Bezel
- LAN / PCMCIA / CF / Audio / USB2.0 / Mini-PCI interfaces
- Resistive and Capacitive touch screens are optional
- Anti-vibration HDD



System

CPU	Onboard VIA C7 1.0 GHz (9W) (up to C7 1.6GHz, 15 W)
Chipset	VIA CN700 + VT8237R plus
BIOS	AMI BIOS Support ACPI Function with PXE function
Cache	Level-1 128K / Level-2 128K (CPU integrated)
VGA	VIA CN700 built-in AGP 8X graphics, shared system memory up to 64MB
Audio	AC97 Audio Codec, 2+2 watts power amplifier
LAN	VT6103 10/100Base-Tx Fast Ethernet PHY, support WOL/PXE function
Memory	1 x DDR2 533 SODIMM socket supports up to 1GB memory
I/O	VIA VT8237R plus
IDE	UDMA 133 EIDE interface x 2 Serial ATA interface x 1
GPIO	4-bit input, 4-bit output
WDT	1~255 minutes, software programmable
H/Monitor	CPU & system temperature monitoring, CPU and system fans speed monitoring

Storage

HDD Internal 2.5" HDD drive bay (PATA interface) x 1

Expansion

Mini-PCI 32-bit Mini-PCI socket
(support 802.11b/g and DVB modules) x 1

PCMCIA PCMCIA Type I/II 32-bit Card Bus slot x 1

CF Bootable Compact Flash slot for CF type I/II storages x 1

Display

Chipset VIA CN700 Integrated Graphics / Video Accelerator

Memory 8/16/32/64 MB frame buffer using system memory

Panel 10": AUO 10.4" TFT LCD (G104SN03, resolution: 800x600, 230 nits)
10"H: AUO 10.4" TFT LCD (G104SN02 V1, resolution: 800x600, 400 nits)

Model	G104SN03 V1	G104SN02 V1
Resolution (pixel)	SVGA (800 x 600)	SVGA (800 x 600)
Active Area (mm)	211.2 x 158.4	211.2 x 158.4
Pixel Pitch (mm)	0.264	0.264
Number of Colors	262K	262K
View Angle (H/V)	140 / 120	140 / 120
Brightness (cd/m2)	230	400
Contrast Ratio	500:1	500:1
Response Time (ms) (at 25°C)	30	35
Interface	1ch LVDS	1ch LVDS
Supply Voltage (V)	3.3	3.3
Backlight	1 CCFL	2 CCFL
Weight (g)	300	495

External I/O

USB USB 2.0 x 4

COM DB-9 x 3 (RS-232 x 2, RS-232/422/485 x 1)

LAN RJ-45 x 1

KB/Mouse PS/2 Keyboard & Mouse x 1

Audio Line-in, Line-out, and Mic-in audio jacks

Power DC-In connector x 1

Switch ATX power switch & RESET switch

Mechanical & Environmental

Power Input DC 12V ~ 28V

Power Adaptor AC90 ~ 264V / 47 ~ 63 Hz

Operating Temperature 0~40 °C (fanless)
0~55 °C (for CF/DOM storage)

Storage Temperature -20~80 °C

Relative Humidity 10%~90%, non-condensing

Dimensions 313(L) x 240(W) x 48.5(D) mm (Resistive type)
313(L) x 240(W) x 51.3 (D) mm (Capacitive type)

Weight 3.5 Kg (Resistive / Capacitive type)

Characteristics	Resistive (4 wire or 5 wire or 8 wire)	Capacitive	Infrared touch (IR)
Touch Resolution	4096x4096	4096x4096	4096x4096
Stylus use possible beyond finger	No Limitation, can use any stylus	Need special conductive stylus	No limitation, can use any stylus
Glove use possible	Any type glove	Only very thin latex glove	Any type glove
Light transmittance	80±3%	90% above	100%
Mohs	3H	7 Mohs	
Accuracy	98.50%	99%	
Response time	20 ms	3 ms	
Touch screen Life	WLP-7821-19 5 wire:35 million touches	Specified to over 200 million touches Coatings can wear	Large number of photo diodes and photo transistors effect long-term reliability. Specified to over 500 million touches Coatings can wear

10" VIA C7 Fanless & Ultra Slim Panel PC

Drawing

10.4" Capacitive TS type

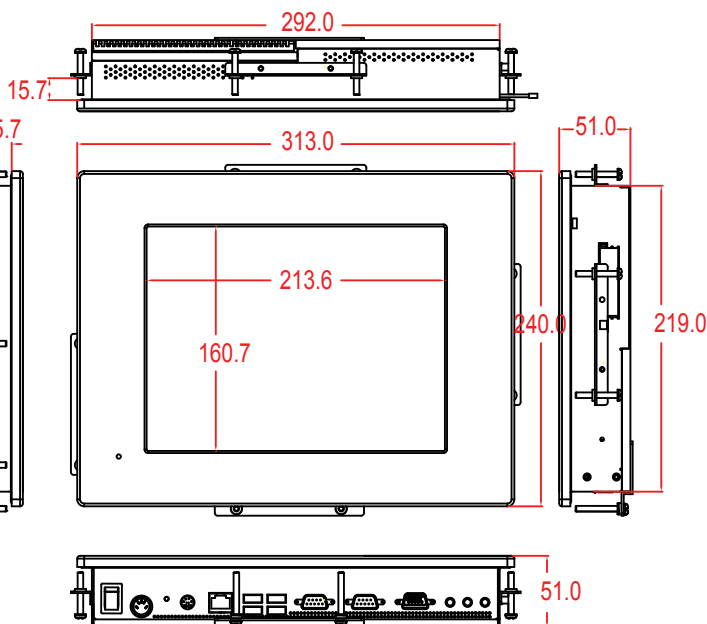
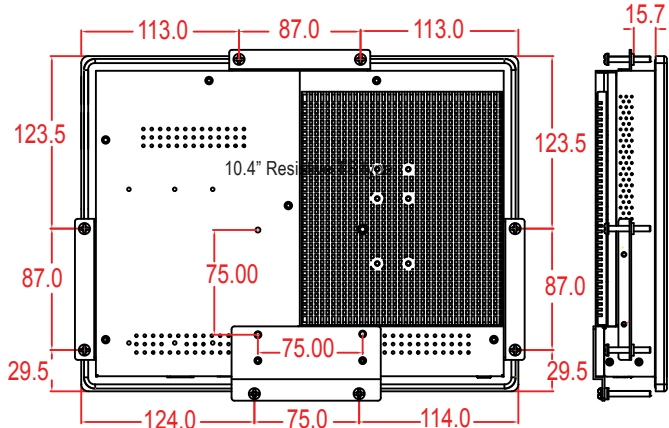

10.4" Resistive TS type

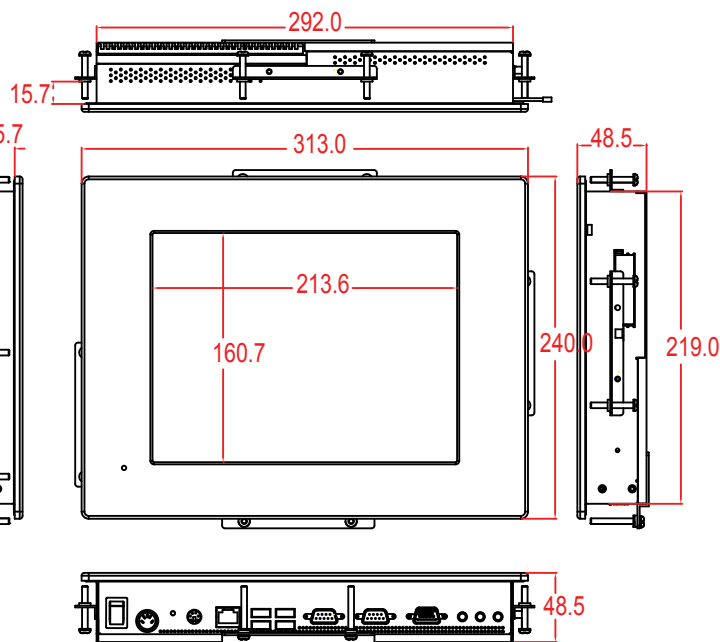
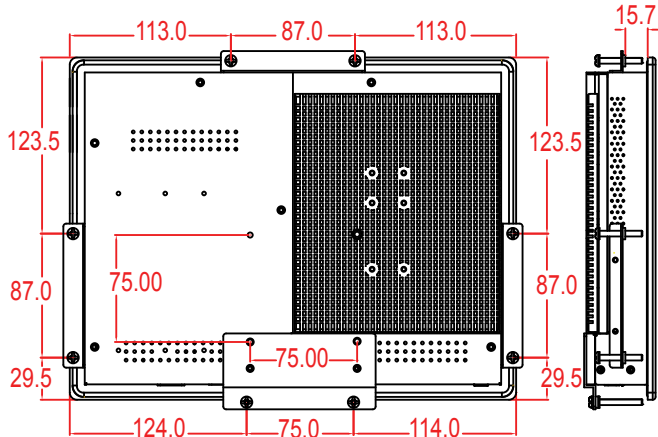

1. Fanless Panel PC

2. Medical All-in-one Solution

3. Engine Box

4. All-in-one Digital Signage Solution

5. XPe Solution

6. Remote Device Management (WRDM)

Fully-integrated I/O

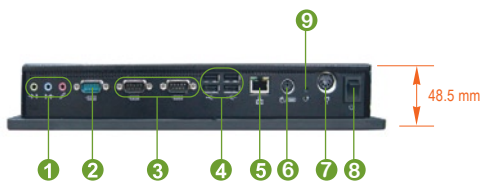
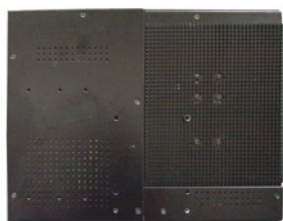

- 1 VGA
- 2 LAN
- 3 USB
- 4 COM
- 5 PS2 K/B
- 6 Power
- 7 VGA
- 8 LAN
- 9 USB

Ordering information

- 1. WLP-6821-10-BKRT-C7 1.0G-512-40 (resistive touch screen)
- 2. WLP-6821-10-BKCT-C7 1.0G-512-40 (capacitive touch screen)
- 3. WLP-6821-10-BKRT-C7 1.5G-512-40 (resistive touch screen)
- 4. WLP-6821-10-BKCT-C7 1.5G-512-40 (capacitive touch screen)

SAW and IR touch screen are also available