

## Modem RS232/RS422/RS485 to MM optic fibers ELO E17A



### Characteristics

- Range up to 6km over MM fiber
- Communication protocol independent
- Point-to-point or ring topology
- User selectable metallic interface
- Desktop or DIN rail versions
- Supply 9-24 V DC

### Introduction

Modem converts the data signals of the duplex interfaces RS232, RS422 and RS422-multidrop as well as a half-duplex interface RS485 to multimode optic fibers with ST optic connectors. It is designed to point-to-point or ring topology.

### Use of the converter

Conversion of metallic media to fiber optic is suitable especially:

- 1) in the high interference level area,
- 2) if the higher isolation is required, (switching stations, transformers),
- 3) if the metallic line can not be used because of EMI ,
- 4) if the higher transport security and safety is necessary,
- 5) if isolation via the optocouplers is not suitable for different reasons,
- 6) to increase a range.

### Operation principles

A pair of modems communicates each other over a duplex multimode optic fiber. The wave length of the signal is 1300 nm. Optic signal has been pulsewidth modulated (PWM).

Communication data ranges for RS232 are 0 – 230 kbps, for RS485/422 from 0 to 2 Mb/s. There are two data indicators Tx and Rx.

Modem doesn't need any setting of data rate or data format parameters if the RS232 interface was set. In the other cases it is necessary to use terminators, pull-up and pull-down resistors according to the metallic line length, data rate or a number of RS485 users.

All the interfaces are connected to a terminal block and can be chosen and activated by the switches.

Terminators, pull-up and pull-down resistors are integrated in modem and they can be used by the switches too.

Data from optic receiver can be copied (echoed) to the transmitter if the ECHO switch was activated. This function is important especially in ring topology.

Power supply of DC 9 – 24 V nominal or 7 – 30 V (limits) has its own clamps.

### Block diagram

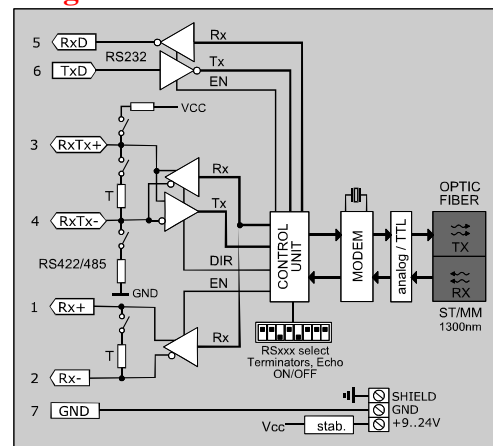

### Specification Parameters

Transmitted signals - RS232	TxD, RxD
Transmitted signals - RS422	Tx+,Tx-, Rx+,Rx-
Transmitted signals - RS485	TxRx+, TxRx-
Type of metallic int. connector	terminal block 3.81mm
Transmit mode	duplex / half-duplex
Fiber optic cable	two multimode fibers 50/125 or 62.5/125 μm
Optic connectors	ST type
Max. range	up to 6km
Max. line attenuation (typ)	9 dB

Maximum data rate of RS232	230 kbit/s
Maximum data rate of RS422/485	2 Mbit/s
Internal terminators	120 Ω
Pull-up, pull-down resistors	1 kΩ
Range of nominal power voltage	9-24V DC /500mA
Limit voltage values	7 – 30 V
Case	metallic box
Length x Width x Height	120x80x25 mm
Weight	160 g

### Other

Stocking temperature	- 10° to +55° C
Working temperature	+ 0° to +50° C
Humidity	0 – 85% (non-condensing)