

CPC108

MicroPC Processor Module

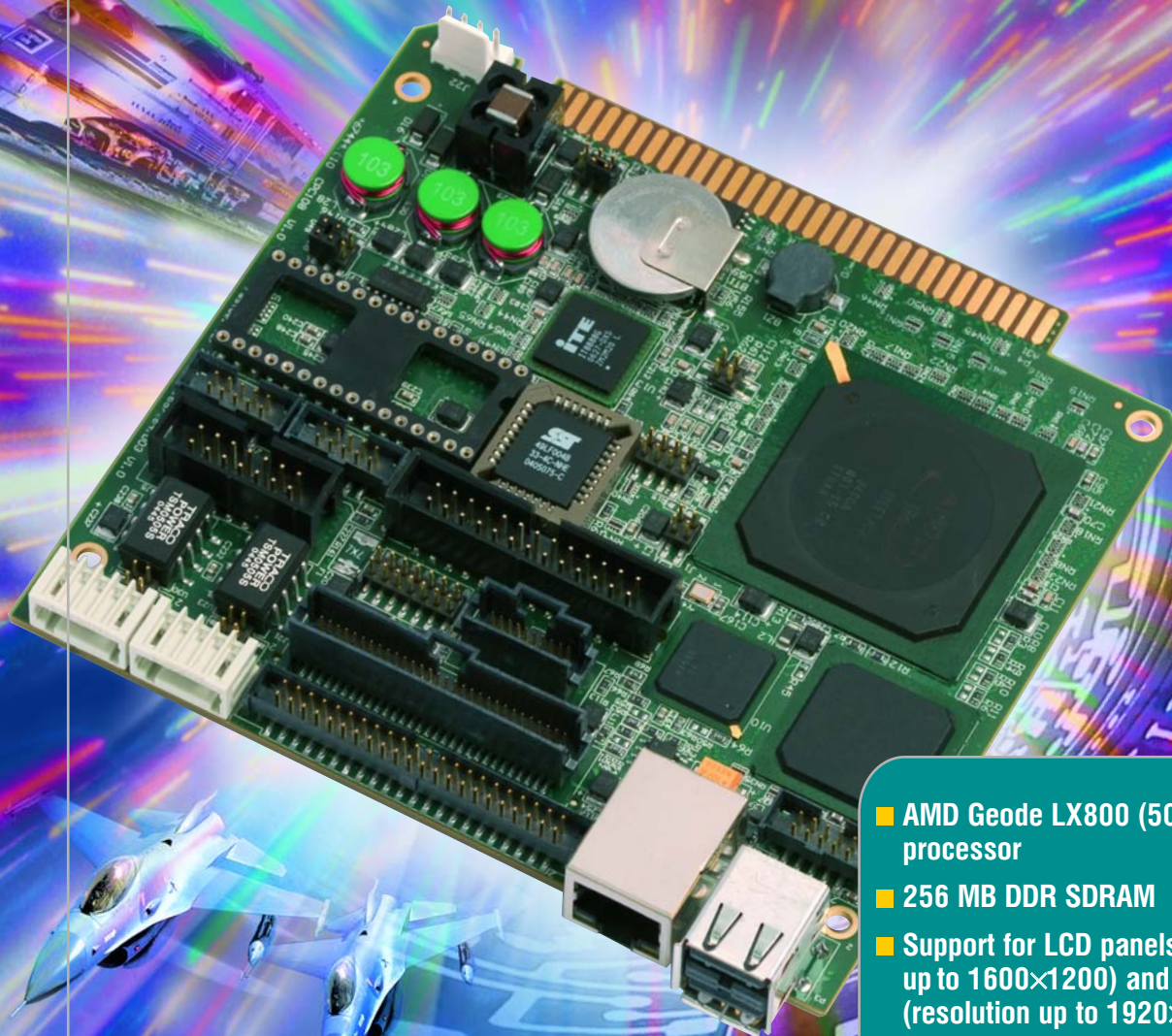
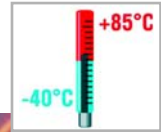

**Best solutions
to fit your demands!**

- AMD Geode LX800 (500 MHz) processor
- 256 MB DDR SDRAM
- Support for LCD panels (resolution up to 1600×1200) and CRT monitors (resolution up to 1920×1440)
- Flash-disk 64 MB
- FDD/LPT (EPP, ECP) interfaces
- USB 1.1, 2.0 support
- Fast Ethernet controller 10/100 Mb/s
- Four COM ports (two isolated)
- Industrial operating temperature range: -40°C to +85°C
- Protective coating (option)



Features

- AMD Geode LX800 (500 MHz) processor
- 256 MB DDR SDRAM
- Support for LCD panels (resolution up to 1600×1200) and CRT monitors (resolution up to 1920×1440)
- Flash-disk 64 MB
- FDD/LPT (EPP, ECP) interfaces
- USB 1.1, 2.0 support
- Fast Ethernet controller 10/100 Mb/s
- Four COM ports (two isolated)
- Industrial operating temperature range: -40°C to +85°C
- Protective coating (option)

Overview

CPC108 is a compact yet fully x86-compatible SBC in MicroPC format, designed for fanless operation in harsh environments. Key system components, such as processor, 256 or 512 MB of system memory, and 64 MB solid-state disk are soldered on board, providing high shock and vibration stability. High system reliability and availability are ensured by two independent watchdog timers, reserved BIOS, and opto-isolated remote reset capability.

CPC108 offers wide choice of standard PC interfaces on-board, such as Fast Ethernet, FDD/LPT port, COM and USB ports, PS/2 mouse and keyboard ports, and audio interface. Video controller sharing up to 60 MB of memory with system supports CRT monitors with resolutions up to 1920×1440, and EL, TFT and DSTN flat panels with resolutions up to 1600×1200. Supported color depth is 18 bit via TFT interface, and 24 bit via LVDS interface.

Moreover, the board has two isolated CAN field bus channels available, allowing to control a real time distributed system. CPC108 can serve either as a master module controlling two CAN network segments, or as a slave device in data acquisition and processing systems operating in industrial temperature range.

Isolated CAN channels, graphics and audio ports, keyboard and mouse ports as well as isolated reset are available through separately mounted interface expansion modules adding flexibility in system design.

CPC108 consumes only 5.5 W, does not require forced cooling. Low heat dissipation allows using CPC108 in closed and hermetically sealed cabinets. It can operate either independently, or together with expansion modules connected via 16-bit ISA bus.

Compatibility with most widespread operating systems, such as Windows XP Embedded, CE, QNX 4.25, 6.3x and Linux makes system development process faster.

Technical Specifications

System

- AMD Geode LX800 (500 MHz): 32-bit x86 core; 64-bit coprocessor; 64-bit memory bus; 64 KB L1 cache; 128 KB L2 cache; MMX®, 3DNow!™ support
- 256 MB DDR SDRAM
- Two watchdog timers: one programmable timer and one hardware timer with fixed timeout period
- Real time clock
- MTBF: 180 000 hours

Flash BIOS

- 2 x 512 KB reserved BIOS
- In-system modification
- CMOS+SFRAM for configuration parameters saving

Graphics

- 2D accelerator
- Up to 60 MB display memory (shared with system)
- LCD (TFT or DSTN) panels support, resolution 1024×768 (60 Hz); 18-bit color connected directly via TFT interface; 24-bit via LVDS interface
- CRT monitors support, 1600×1200 (100 Hz), 1920×1440 (85 Hz, 32-bit)

Storage

- Flash-disk: 64 MB
- EIDE interface: handles up to two devices (Primary channel), UltraDMA/100 support
- CompactFlash socket
- DiskOnChip® socket: SRAM and FRAM (32/28 pins) modules support
- Isolated reset

Software Support

- Fastwel DOS™ (MS™ DOS compatible)
- QNX® 4.25, 6.3x
- Windows® XPE
- Windows® CE
- Linux®

Interfaces

- Fast Ethernet controller 10/100 Mb/s
- USB 1.1, 2.0 support, up to four devices connection; 3 host ports, 1 host/device
- Serial ports:
COM1, COM2: RS232, complete, up to 115.2 Kb/s
COM3, COM4: RS422 / RS485, isolated
- Console operation via COM1 or COM2 serial ports
- Two CAN ports: available via KIB985 module, isolated
- AC97 compatible audio: stereo Line in/Line out, microphone input
- PS/2 keyboard and mouse port
- FDD / LPT (EPP, ECP) interfaces share one connector

Mechanical

- Dimensions: 125.0 × 123.0 × 23.0 mm (4.92" × 4.84" × 0.90")
- Weight: 0.100 kg

Power Supply Options

- 5 V ±5%, 1.3 A

Environmental conditions

- Operating temperature: -40°C to +85°C
- Storage temperature: -55°C to +90°C

Warranty

- 3 years for parts and labor

List of deliverables

- CPC108 processor module
- ACS00023 – cable for connection to COM1, COM2 ports
- ACS00010 – cable for connection of 2.5" HDD
- CDM02 – adapter module for connection of 3.5" HDD and CD-ROM
- KIB981 – interface expansion module for connection of TFT panel or VGA monitor, PS/2 keyboard and mouse, audio devices
- ACS00015 – cable for connection of KIB981 module
- CD-ROM with documentation and service SW

Board Layout

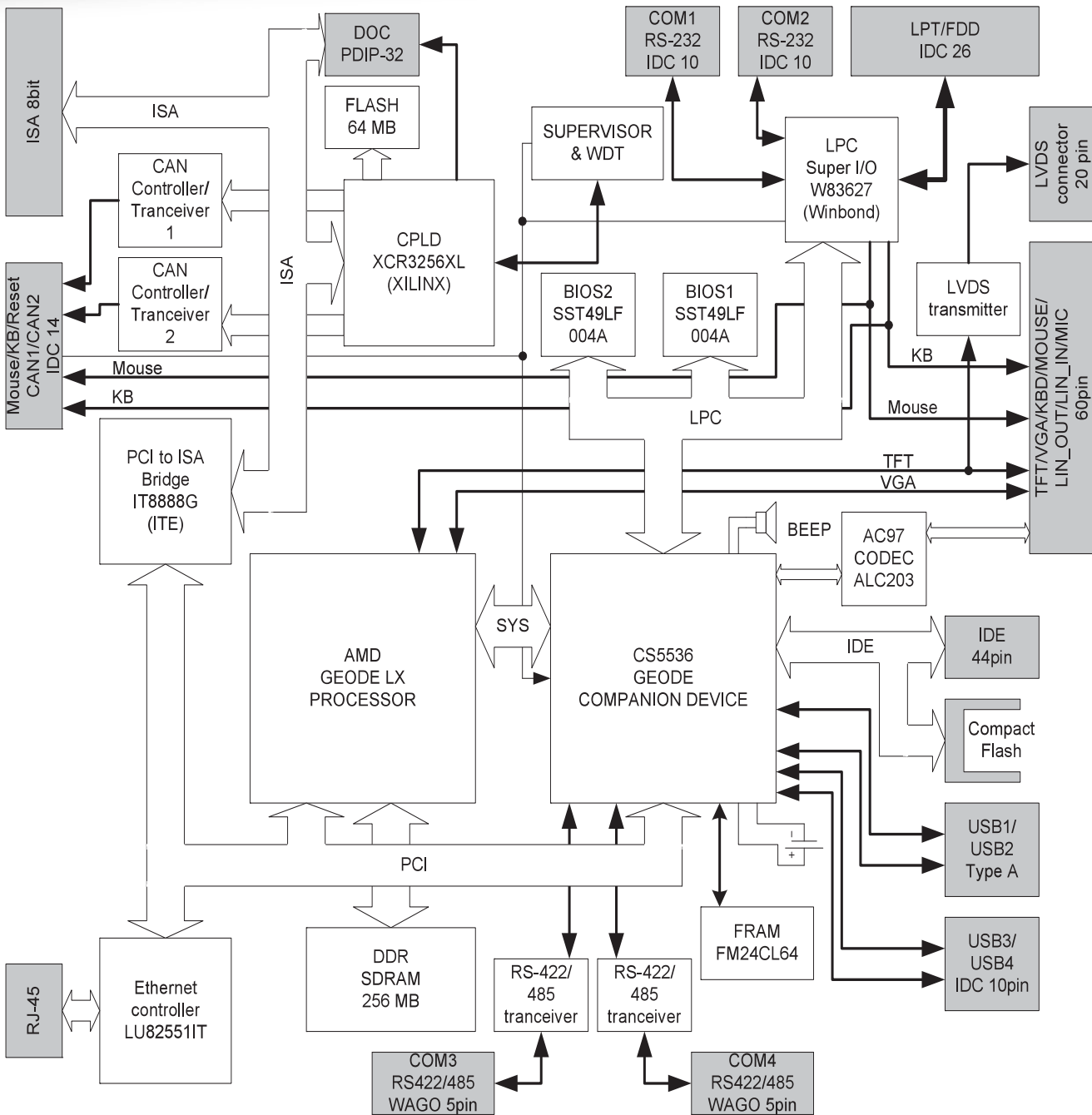

Expansion Capabilities

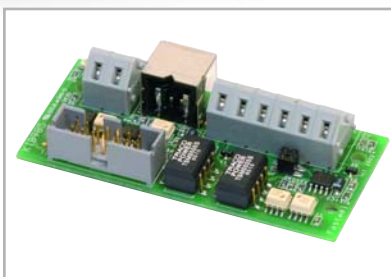

KIB985 module is designed for connecting following devices to CPC108:

- Keyboard and mouse PS/2 (MiniDIN6 socket, requires Y-cable for simultaneous connection)
- CAN2.0B network (socket for WAGO 236-406 spring clip with opto-isolation up to 1000 V between channels and system, and termination resistor 120 ohm connectivity for CAN1: JP1[1-2]=ON, for CAN2: JP1[3-4]=ON)
- RESET signal with active level from 3.3 V to 12 V (socket for WAGO 236-402 spring clip, isolation up to 1500 V)

The module is equipped with adapters for DIN-pail mounting and holes for crate mounting (F520x (Fastwel) and 520x (Octagon Systems) series crates).



Ordering Information

CPC108 Configuration

CPC10801 \Options

Device Type

CPC10801	CPC108, Dual CAN, Ethernet 10/100, LVDS
CPC10802	CPC108, Dual CAN
CPC10803	CPC108, Ethernet 10/100

CPC108 Available Options

Compact Flash Module	
\CF1024	1024 MB Compact Flash, industrial
\CF2G	2 GB Compact Flash, industrial
\CF4G	4 GB Compact Flash, industrial
\CF8G	8 GB Compact Flash, industrial
\CF16G	16 GB Compact Flash, industrial
Coating	
\COATED	Protective Coating
Operating System Presetting	
\FDOS	Fastwel DOS
\QNX	QNX 6.3x, 4.25
\WCE	Windows CE
\WXPE	Windows XP Embedded
\LNX	Linux 2.4.20

Other configurations and options are available upon request.

Example

CPC10801 \COATED

MicroPC, AMD Geode LX800 Module, Dual CAN, Ethernet 10/100, LVDS
Protective coating

Ver. 1.8 2008

Product specifications are subject to change without notice

Applications



Embedded



Process Control



Avionics



Transportation

Corporate Offices

FASTWEL GROUP Company Limited

108 Profsoyuznaya str.
Moscow, Russia 117437
Tel: +7 (495) 232-1681
Fax: +7 (495) 232-1654
E-mail: info@fastwel.com
Web: www.fastwel.com

FASTWEL Corporation US

45 Main Street, Suite 319
Brooklyn, New York 11201
Tel: 1.718.554.3686
Fax: 1.718.797.0600
Toll free: 1.877.787.8443
(1.877.RURUGGED)
E-mail: info@fastwel.com

READY FOR



RoHS



Fastwel



Fastwel



Fastwel