

MIP470

400 MHz PowerPC Board with FPU

General Description

The MIP470 is a rugged embedded industrial SBC in PC/104 form factor. As processor the Freescale MPC8347E PowerPC™ with integrated FPU is used. The solution is ideal for applications requiring small size, high performance and low power. For easy cooling the CPU is placed on the bottom of the board. All components required to build an industrial PC system are already on-board. The available PCI-104 interface offers easy and flexible expansion capabilities. Integration of the MIP470 into a system is facilitated by the fact of offering standard connectors for E-IDE, USB2.0 and Gigabit Ethernet. The four serial interfaces can be accessed through 2 mm headers. The particularly design fulfills the CE, FCC and MIL810F requirements. The DDR2 SDRAMs are soldered on board and are ECC protected.

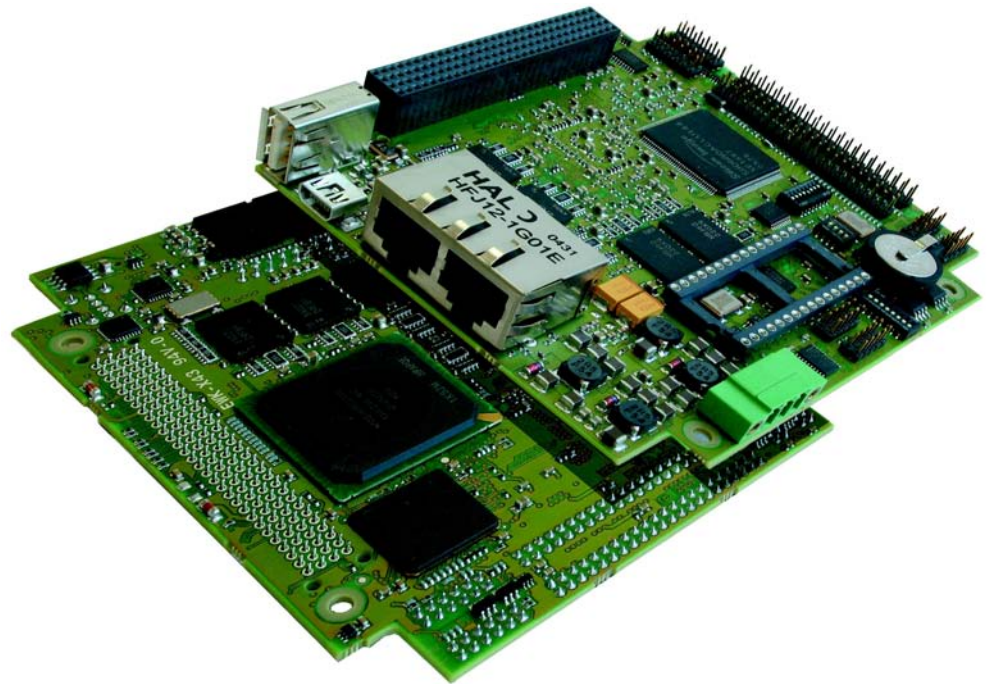

MIP470 fully equipped PCI-104 board

MIP470 Capabilities

The board has been specifically designed to be rugged for harsh environments.

Unique features:

- Low power CPU with FPU (typ. 6,5W)
- On-board ECC SDRAM and Flash
- 2 x Gigabit Ethernet & 2 x USB2.0
- 4 serial ports (RS232/TTL)
- Various boot sources
- Socket (MPS) for additional SRAM, Flash, EPROM on-board

Those features make

the MIP470 ideal for any embedded control application requiring small size, high performance and low power. The products are being used in aviation and transportation systems, industrial or any other rugged/secure application like medicine.

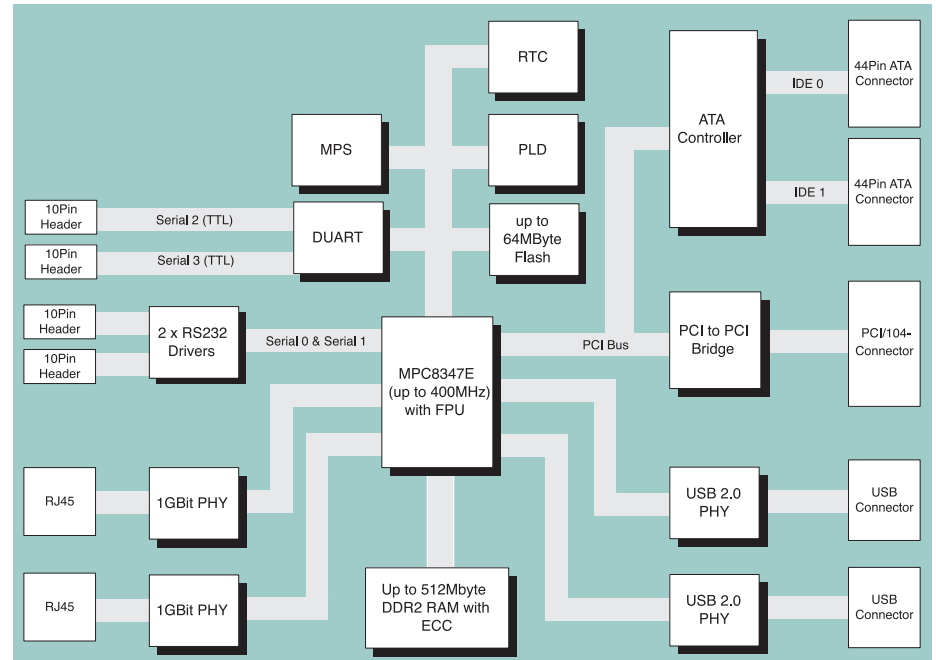

Technical Features MIP470

Board Key Data

Processor	PowerPC MPC8347E with FPU	Embedded processor from Freescale
CPU Speed	up to 400 MHz	750 MIPS @ 400 MHz
FLASH	up to 64 MB Flash EEPROM	63.5 MB free user space for boot kernel
Memory	up to 512 MB ECC DDR2 266 SDRAM	Soldered on-board
RTC	backed with on-board battery	Environment can be saved in EEPROM
Ethernet	2 x Gigabit Ethernet ports 10 Base T / 100 Base Tx / 1000 Base T	RJ45 connectors, ESD protected Support IEEE802.3 auto negotiation
USB2.0 Ports	1 x Type A Host, 1 x Type AB (OTG)	ESD protected
Serial Ports	2 ports RS232 2 port with TTL signaling	All available over 10-pin 2 mm header Two with full modem handshake signals
E-IDE Port	2 ports PIO mode 4, Bus Master IDE	Standard 44-pin header
Expansion	32-bit PCI-104 interface (PCI-Host)	For up to 4 Busmaster cards
Indicator	8 activity LED's + 1 user definable	Power, Reset, Error, HDD, 4 x LAN, User
Multi Purpose Socket (MPS)	for additional SRAM, FLASH or EPROM	32-pin DIL memory components

Physical / Power

Size (length x width x height)	95.9 x 115.6 x 14 mm 3.775 x 4.550 x 0.550 inch	PC/104-Plus compliant None stack through module
Weight	110g	Fully equipped MIP470
Power	+5VDC ± 5%	Over power connector or PCI-104
Power consumption	typically <6.5W @ 400 MHz	with 512MB RAM & 64MB Flash
Temperature Range	-20°C up to +60°C, fanless	Optional extended temperature
Humidity	5% to 95% non condensing	Optional coating available

Standard Compliance

The MIP470 is designed to meet or exceed the most common standards. Particular references are:

EMC	EN 55022, EN 55024, EN 61000, MIL-STD-461E
Shock & Vibration	EN 60068
Environmental & Safety	EN 50155, MIL-STD-810-F, EN 60601, EN 60950
Approval Lists	CE, EN 60945, IACS E10

MIP470 versions

- Complete version
- Depopulated versions
- Coated versions
- Extended temp. versions

Expansions & Options

- Over the PCI-104
- Graphic module
- PC Card module
- Any Digital or Analog I/O board

Operating systems

- Various LINUX distributions
- Real Time LINUX
- Realtime OS (QNX...)
- Open source boot loader for other OS

The MIP470 is fully developed, designed and produced by MPL AG in Switzerland.
For other requirements contact MPL.

Other MPL Products

PC/104 Peripherals	PC/104 and PC/104-Plus peripheral solutions (4/8 x serial lines, single & dual LAN, PC card, ...) IDE based memory storage solutions (CF, PCMCIA).
Industrial PCs	Fanless, rugged Packed Industrial PCs with Intel CPUs in various housings and with many accessories. Products for extended temperature (-40° up to +75°C) and with long-term availability.
Panel PCs	Fanless, IP65/NEMA4 protected Panel PCs (all around). Solutions with 6" - 19" LCDs and Touch in special aluminum or stainless steel case.
Engineering & Support	Professional engineering, support and consulting through MPL engineers on Hardware and Software.

MPL AG is an ISO9001 certified company



MPL AG, Täferstrasse 20, CH-5405 Baden-Dättwil
Tel. +41 (0)56 483 34 34, Fax +41 (0)56 493 30 20
Email: info@mpl.ch, Home page: www.mpl.ch