

UEIPACubes and RACKs

Programmable Automation Controllers

- Powerful stand-alone embedded controller
- Flexible, compact and rugged
- Standard Linux or VxWorks Operating System
- IOT/MQTT ready (pre-installed Mosquito app)
- DDS support with ZeroMQ, OpenSplice or CoreDX.
- EPICSCAS support included
- Optional 8347E for HW accelerated ethernet encryption
- Web/HTML/HTML5 Web Socket interface support.
- Flexible: Over 70 I/O boards available
- Solid-State Drive and/or SDCard-based storage
- 100Base-T, 100Base-FX (fiber), or Gigabit Ethernet
- Synchronization via IEEE-1588 (RTLinux 4.4.115 kernel)
- Xenomai or kernel-based real-time capability in Linux
- Ideal for HIL (Hardware In the Loop) applications



Now available with a Solid-State Hard Drive!!

General Description:

The UEIPAC offers an unprecedented combination of flexibility, high performance, low cost and small size. The unit is an ideal solution in a wide variety of measurement and control applications including: Temperature control, Remote/unmanned vehicle control, Hardware in-the-loop (HIL) and more. The UEIPAC is also an ideal solution for a host of embedded DAQ applications as it allows systems to be developed without the cost or the additional space required by an external host computer. The UEIPAC supports both VxWorks and Linux operating systems.

The UEIPAC is available on all UEI's platforms!

A key advantage of the UEIPAC is its standalone application deployment. In PowerDNA systems, the software application is written for, and runs on a host PC that is connected to one or more UEI chassis via Ethernet. In UEIPAC systems, the Linux/VxWorks application runs directly on the UEI RACK or Cube. There is no need for a separate host PC, though you can certainly connect one in a monitoring or supervisory role. This allows smaller, faster, more reliable and higher performance systems. It also eliminates the cost of a dedicated host PC and guarantees

long term availability of the identical hardware. This is critical when certifying products through CE or FDA, etc.

Linux Systems

- Uses standard 4.4.x Linux kernel with Xenomai 3.05 and Real-Time Linux 4.4.115 real-time support
- Program in standard C/C++
- Eclipse IDE support
- Develop on Linux PC or Windows PC in the Cygwin environment

VxWorks Systems

- Use your existing development license
- Obtain your run-time license from WindRiver
- Our BSP provides everything else you need including an assortment of helpful examples
- One-time charge for the BSP regardless of number of systems deployed

Hardware Block Diagram (UEIPAC300/600)

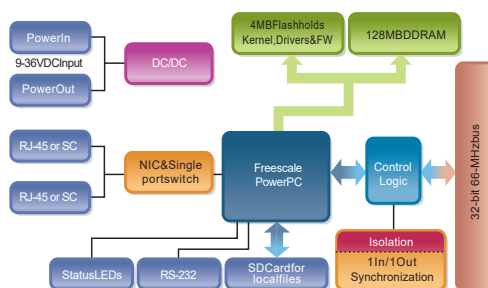

The heart of every UEIPAC is a 5200 or 8347 PowerPC processor running a standard VxWorks or Linux OS. An 8347E version is available for applications requiring encryption. Flash memory contains the OS Kernel and drivers for each of the I/O boards. The CPU board also provides an SD Card slot, Ethernet interface, Inter-cube trigger/sync interface, RS-232

serial port as well as the power supply inputs and a variety of annunciator LEDs. Optional 8 and 16 GByte solid-state hard drives are also available on GigE based units. The file system which is contained on the SD card or SSD (GigE only), includes the other components of the operating system such as libraries, utilities, init script and daemons. The GigE Cubes and RACKS provide a USB 2.0 port usable with external hard drives or memory sticks. Synchronization is possible via sync connector or IEEE-1588.

The UEIPAC is supported by all UEI DNA/DNR/DNF series chassis and uses the same I/O boards. There are currently over 70 different I/O boards available including analog input (with up to 24 bit resolution), analog output, digital I/O, MIL-STD-1553, AFDX, ARINC 429/453/708, Serial and CAN communications, counter/timer, quadrature encoder input and more. With this many different I/O boards available, there is sure to be a configuration perfect for your application.

The GigE Cubes and RACKS provide dual Ethernet ports, each of which resides at a unique IP address. These are most commonly used to provide separate primary control and diagnostic ports but can also function as teamed/bonded redundant interfaces.

Linux Programming

Your application runs as a regular Linux process giving you access to the standard POSIX API provided by the GNU C runtime library (glibc) as well as any other library that can be compiled for Linux (for example: libxml, libaudio file...).

The UEIPAC includes an EPICS (Experimental Physics and Industrial Control System) Channel Access Server (CAS). The LibSharedData software allows easy connection of the UEIPAC to HTML/HTML5 browsers via Web Sockets or other PCs via TCP/IP sockets.

Whether your application requires a few I/O channels or a few thousand, the UEIPAC is an ideal solution. The UEIPAC's unique combination of Linux operating system, real-time support, I/O flexibility, compact size, mechanical and electrical ruggedness, and ease of use is unparalleled.

UEIPAC Linux TK Programmer's Toolkit

The programmer's toolkit provides the software tools necessary to create an embedded application targeting Linux on the UEIPAC's PowerPC processor. This includes most popular versions of Linux such as Fedora and Suse. The development environment runs on a Linux PC or in the Cygwin environment on a Windows PC. The UEIPAC is also supported by the popular Eclipse IDE. Applications requiring hard real-time functionality are possible using the Xenomai 3.05 Linux extension or the Real-Time Linux capability included in the 4.4.115 series kernel. The RTLinux kernel must be used for proper IEEE-1588 performance.

The UEIPAC development environment includes:

- GCC 6.3.0 based cross-compiler for applications targeting the UEIPAC PPC module
- GNU toolchain tools such as make
- Standard Linux libraries such as glibc
- UEIPAC library for the various I/O boards/devices

The UEIPAC Linux TK is not included with the UEIPAC and must be purchased as a separate item. **Only one Linux toolkit must be purchased, regardless of the number of UEIPACs deployed.**

The toolkit uses the same API as our popular PowerDNA Cubes, allowing you to reuse existing programs that were designed to run with a PowerDNA Cube over the network. This allows you to develop your application on your desktop, working directly with a "slaved" PowerDNA Cube. Once you are satisfied with your system, you may port the programs to run directly on the UEIPAC Cube with few modifications.

After the UEIPAC power-up, you have a ready-to-go Linux OS with FTP and web servers as well as a command line shell accessible from the serial port or telnet and SSH over the network.

EPICS

(Experimental Physics and Industrial Control System) is popular standard in high-energy physics laboratories. Our new EPICS server provides the source code to set up the UEIPAC as an EPICS CAS (Channel Access Server), allowing you to configure any I/O input or output as a PV (Process Variable).

Eclipse IDE support

The UEIPAC is now supported by the Eclipse IDE. Programmers may now take advantage of the many powerful Eclipse tools to build their UEIPAC applications.

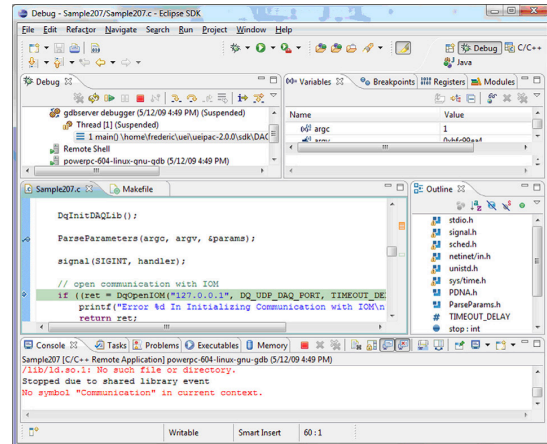

The Eclipse IDE debug screen.

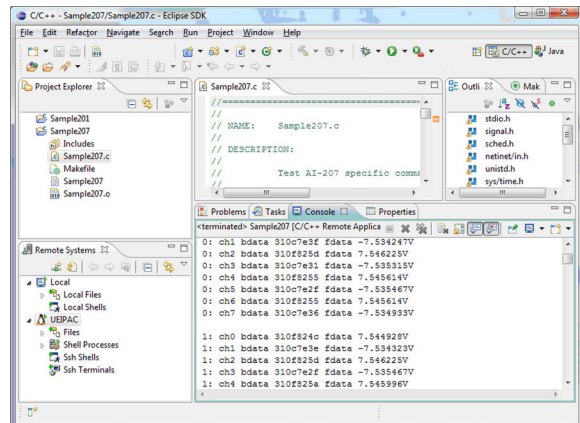

A typical Eclipse IDE run-time screen.

New Software Support

Web Browser Interface: Our new LibSharedData API/library allows easy connection of the UEIPAC to HTML/HTML5 browsers via Web Sockets or other PCs via TCP/IP sockets. The HTML5 interface is fully compatible with many "mobile" browsers including Safari for iOS and iPhones and iPads and the Android web browser. Of course the standard HTML interface is provided to interface to more general purpose web browsers.

IOT

The UEIPAC comes with Mosquitto pre-installed. Mosquitto implements a broker and a C library to publish/subscribe MQTT messages. Examples and API documentation can be found at <http://mosquitto.org>. UEIPAC comes with the SampleDMap_MQTT example that can acquire and publish data from AI, DI or counter/timer layers. The example can also subscribe to external data and write it on AO and DO outputs.

VxWorks Programming

You may now take advantage of all the hardware advantages of UEI's popular UEIPAC chassis and continue to develop your applications in VxWorks. This powerful combination provides hard real-time performance, an extremely robust and reliable operating system, allows you to develop your application in a familiar environment and last, but not least, allows you to preserve a great deal of previously written code! To deploy a UEIPAC application running VxWorks you'll need the following.

1. A UEIPAC* (any version with GigE Ethernet ports)
2. The "UEIPAC VxWBSP". You only need to purchase the BSP once, regardless of the number of systems you deploy
3. A VxWorks v 6.9.x development system (from Wind River)
4. A VxWorks run-time license for each UEIPAC deployed. (also purchased from Wind River)

Though it's beyond the scope of the datasheet to provide details on how to configure and program the UEIPAC in VxWorks, the following is the table of contents from the current revision of the VxWorks UEIPAC user manual. The steps mentioned should be familiar to existing VxWorks programmers and should help the reader understand the process.

1 Configuring and building a VxWorks kernel for UEIPAC

1.1 Installing Software

- 1.1.1 Extract files
- 1.1.2 Build PowerDNA driver

1.2 Building a VxWorks kernel for UEIPAC

- 1.2.1 Create a VxWorks Image Project
- 1.2.2 Kernel Configuration
- 1.2.3 Build Kernel

1.3 Booting VxWorks kernel on UEIPAC

- 1.3.1 Manual boot
- 1.3.2 Store kernel in flash
- 1.3.3 Automatic boot in VxWorks

2 Programming with PowerDNA API

- 2.1 Building PowerDNA library
 - 2.1.1 Set-up environment
 - 2.1.2 Install PowerDNA driver source and documentation
 - 2.1.3 Build library using DIAB tools
 - 2.1.4 Build library using GNU tools

2.2 Building an example as a kernel module

- 2.2.1 Creating workbench project
- 2.2.2 Running the example
- 2.2.3 Debugging the example

*UEIPAC CPU option 03 is not currently supported by VxWorks. Please contact UEI if your application requires VxWorks support on an "03" version of the CPU.

UEIPAC: Technical Specifications

Computer Interface	MIL series ruggedized chassis
Primary Ethernet Port	10/100/1000 Base-T, 38999 connector
Diagnostic Port	10/100/1000 Base-T, 38999 connector
Net Teaming/bonding	Supported in both Linux and VxWorks deployments
Config/Serial Port	on LAN/COM 38999 connector
USB Port	USB 2.0 fully supported
Synch Options	Sync input/output port or IEEE-1588 (requires use of RTLinux 4.4.115 kernel)
I/O Board Support	
Series supported	All DNR/DNA-series boards as appropriate
Software / Operating System	
Embedded OS	Linux, kernel 4.4.71 or VxWorks 6.9.x
Real-time support	Xenomai 3.05 or 4.4.115 kernel based Real-time Linux, VxWorks is a real-time OS
EPIC SCSI interface	Yes (Linux version)
SNMP Library	Yes
Processor/system	
CPU	Freescale 8347 or 8347E, 400 MHz, 32-bit
Memory	256 MB, 228 MB available to user apps.
FLASH memory	32 MB standard / 128 MB optional 24 MB / 120 MB available for user apps.
Solid-State Hard Drive	Optional 8 or 16 GB drives available*
SD card interface	SD cards up to 32 GB
USB drive interface	Standard USB 2.0 port
Physical Dimensions	
4 I/O slots	UEIPAC400-MIL: 6.2" x 7.1" x 8.7", 11 lbs.
6 I/O slots	UEIPAC600-MIL: 10.6" x 7.0" x 6.4", 16 lbs.
12 I/O slots	UEIPAC1200-MIL: 17.5" x 8.1" x 7.0" 22 lbs.
Environmental	
Temp (operating) UEIPAC1200-MIL	-40 °C to 85 °C (power dissipation of actual system may require derated max temp.)
Temp (operating) UEIPAC400-MIL	-40 °C to 70 °C (power dissipation of actual system may require derated max temp.)
Temp (operating) UEIPAC600-MIL	-40 °C to 70 °C (power dissipation of actual system may require derated max temp.)
Temp (storage)	-40 °C to 85 °C
Humidity	0 to 95%, non-condensing
Vibration	MIL-STD-810G plus the IEC specs below
(IEC 60068-2-64)	10-500 Hz, 5g (rms), Broad-band random
(IEC 60068-2-6)	10-500 Hz, 5g, Sinusoidal
Shock	MIL-STD-810G plus the IEC specs below
(IEC 60068-2-27)	100 g, 3 ms half sine, 18 shocks at 6 orientations; 30 g, 11 ms half sine, 18 shocks at 6 orientations
EMI / RFI	Designed to meet MIL-STD-461
Altitude	70,000 feet, maximum
Sealing	Default unit sealed to IP66 or better. Pressure relief valve support continuous altitude changes of 5000 fpm. Units can be configured with bottom weep holes if desired.
Power Requirements	
Voltage	9 - 36 VDC designed to meet MIL-1275 / 704
Reliability	
MTBF 400-MIL	>100,000 hours
MTBF 600-MIL	>100,000 hours
MTBF 1200-MIL	>130,000 hours

UEIPAC: Technical Specifications

Computer Interface	UEIPACxxx series Cubes	UEIPACxxx-1G series GigECubes	RACKtangle Chassis
Primary Ethernet Port	10/100Base-T, RJ-45 connector	10/100/1000Base-T, RJ-45 connector	10/100/1000Base-T, RJ-45 connector
Diagnostic Port	not applicable	10/100/1000Base-T, RJ-45 connector	10/100/1000Base-T, RJ-45 connector
Other Port functions	Daisy chained single port switch provided	Ports may optionally be bonded/teamed	Ports may optionally be bonded/teamed
Optional Interface	100Base-FX Fiber (single or multi mode)	n/a	n/a
Config/Serial Port	RS-232, 9-pin "D"	RS-232, 9-pin "D"	RS-232, 9-pin "D"
USB Port	not supported	USB 2.0 fully supported	USB 2.0 fully supported
Synchronization Options	1. DNA-SYNC series cables/boards provide system clock or trigger synchronization. 2. DNA-IRIG-650 for IRIG and GPS synchron. 3. NTP using standard Linux functionality	1. DNA-SYNC-1G series cables and boards provide both clock and trigger sync signals. 2. DNA-IRIG-650 for IRIG and GPS synchron. 3. IEEE-1588 synchronization, requires use of RTLinux 4.4.115 kernel	1. DNA-SYNC-1G series cables and boards provide both clock and trigger sync signals. 2. DNA-IRIG-650 for IRIG and GPS synchron. 3. IEEE-1588 synchronization, requires use of RTLinux 4.4.115 kernel
I/O Board Support			
Series supported	All DNA-series boards	All DNA-series boards	All DNR-series boards (DNF for FLATrack)
Software / Operating System			
Embedded OS	Linux, kernel 4.4.x or VxWorks 6.9.x	Linux, kernel 4.4.x or VxWorks 6.9.x	Linux, kernel 4.4.x or VxWorks 6.9.x
Real-time support	Xenomai 3.05 or 4.4.115 kernel based Real-time Linux, VxWorks is a real-time OS	Xenomai 3.05 or 4.4.115 kernel based Real-time Linux, VxWorks is a real-time OS	Xenomai 3.05 or 4.4.115 kernel based Real-time Linux, VxWorks is a real-time OS
Dev Language	C/C++, C++11/14/17, Eclipse IDE support	C/C++, C++11/14/17, Eclipse IDE support	C/C++, C++11/14/17, Eclipse IDE support
Dev Environments	Linux PC or Cygwin Windows environment	Linux PC or Cygwin Windows environment	Linux PC or Cygwin Windows environment
EPIC SCA Interface	Yes	Yes	Yes
SNMP Library	Yes	Yes	Yes
Processor/system			
CPU	Freescale MPC5200, 400 MHz, 32-bit	Freescale 8347 or 8347E, 400 MHz, 32-bit	Freescale 8347 or 8347E, 400 MHz, 32-bit
RAM Memory	128 MB, 100 MB available to user apps	128 MB standard / 256 MB optional 100 MB / 228 MB available to user apps.	128 MB standard / 256 MB optional 100 MB / 228 MB available to user apps.
FLASH memory	4 MB (0 MB available for user apps)	32 MB standard / 128 MB optional 16 MB / 112 MB available for user apps.	32 MB standard / 128 MB optional 16 MB / 112 MB available for user apps.
Solid-State hard drive	not available	Optional 8 or 16 GB drives available*	Optional 8 or 16 GB drives available*
SD card interface	SD cards up to 32 GB (8 GB included)*	SD cards up to 32 GB (8 GB included)*	SD cards up to 32 GB (8 GB included)*
USB drive interface	n/a	Standard USB 2.0 port	Standard USB 2.0 port
Physical Dimensions			
1 I/O slot		UEINET-PAC: 4.1" x 4.0" x 2.7"	
3 I/O slots	UEIPAC300: 4.1" x 4.0" x 4.0"	UEIPAC300-1G: 4.1" x 5.0" x 4.0"	n/a
4 I/O slots			UEIPAC400R: 1.75" x 7.8" x 16" (Std 1U)
6 I/O slots	UEIPAC600: 4.1" x 4.0" x 5.8"	UEIPAC600-1G: 4.1" x 5.0" x 5.8"	UEIPAC600R: 5.25" x 6.2" x 10.5"
7 I/O slots	UEIPAC700: 4.1" x 4.0" x 6.6"	UEIPAC700-1G: 4.1" x 5.0" x 6.6"	
12 I/O slots	n/a	n/a	UEIPAC1200R: 5.25" x 6.2" x 17.5" (Std 3U)
Environmental			
Electrical Isolation	350 Vrms	350 Vrms	350 Vrms
Temp (op/storage)	-40 °C to 85 °C / -40 °C to 100 °C	-40 °C to 70 °C / -40 °C to 85 °C	-40 °C to 70 °C / -40 °C to 85 °C
Humidity	0 to 95%, non-condensing	0 to 95%, non-condensing	0 to 95%, non-condensing
Vibration			
(IEC60068-2-64)	10–500 Hz, 5 g (rms), Broad-band random	10–500 Hz, 3 g (rms), Broad-band random	10–500 Hz, 3 g (rms), Broad-band random
(IEC60068-2-6)	10–500 Hz, 5 g, Sinusoidal	10–500 Hz, 3 g, Sinusoidal	10–500 Hz, 3 g, Sinusoidal
Shock			
(IEC60068-2-27)	50 g, 3 ms half sine, 18 shocks at 6 orientations; 30 g, 11 ms half sine, 18 shocks at 6 orientations	100 g, 3 ms half sine, 18 shocks at 6 orientations; 30 g, 11 ms half sine, 18 shocks at 6 orientations	100 g, 3 ms half sine, 18 shocks at 6 orientations; 30 g, 11 ms half sine, 18 shocks at 6 orientations
Altitude	70,000 feet (special version to 120,000')	70,000 feet, maximum	70,000 feet, maximum
Power Requirements			
Voltage	9-36 VDC (115/220 VAC adaptor included)	9-36 VDC (115/220 VAC adaptor included)	9-36 VDC (115/220 VAC adaptor included)
Power	3.5 Watts (not including I/O boards)	7 Watts (not including I/O boards)	10 Watts (not including I/O boards)
Reliability			
MTBF	>300,000 hours	>160,000 hours	>130,000 / 160,000 hrs DNR-12/ DNR-6

*THE SD CARDS AND SSD DEVICES USED ARE NOT BUILT BY UEL AS MEDO. NOT CONTROL THE SOURCE, WE CANNOT OFFER OUR 10 YEAR AVAILABILITY GUARANTEE ON THESE DEVICES.

Extended Features:

Easy to configure and deploy

- Standard Linux operating system (VxWorks Available)
- Eclipse IDE support
- IOT ready with pre-installed MQTT support
- Supports DDS packages including ZeroMQ, OpenSplice and CoreDX
- Xenomai RTOS support
- EPICSCAS provided
- Web server
- Web Browser (Web Socket) interface included
- FTP server included
- Over 70 different I/O boards available
- Built-in signal conditioning
- Optional 8 or 16 GB Solid-State hard drives
- Standard SDCard file interface
- Flange kit for mounting to wall/flat surface
- DIN rail and Rack Mount kits
- Standard "Off-the-shelf" products and delivery

Flexible Connectivity

- 100Base-Tor GigE with Cat-5 cable
- RS-232 Interface
- 10/100Base-FX Fiber interface available
- Supports Wi-Fi / GSM/ Cell networks

Rugged and Industrial:

- 100Base-T Cube operation tested from -40 °C to 85 °C
- RACK and GigE Cube operation tested from -40 °C to 70 °C
- 100Base-T Cube Vibration tested to 5 g
- RACK and GigE Cube Vibration tested to 3 g
- Shock tested to 100 g (operating)
- 100Base-T Cube Operation to 120,000 feet (special version Cube)
- 100Base-T Cube radiation tested for space applications

Compact Size and High Channel Density:

- Analog Inputs: up to 175/300 chan. per Cube/RACKtangle
- ICP/IEPE: up to 28/48 channels per Cube/RACKtangle
- Analog Outputs: up to 224/384 chan. per Cube/RACKtangle
- Digital I/O: up to 336/576 DIO per Cube/RACKtangle
- ARINC429: up to 112/192 channels per Cube/RACKtangle
- Counter/Timer: up to 56/96 counter channels per Cube/RACKtangle
- CAN-bus: up to 28/48 ports per Cube/RACKtangle
- RVDT/LVDT: up to 28/48 channels per Cube/RACKtangle
- RS-232/422/485: up to 56/96 ports per Cube/RACKtangle
- Synchro: up to 28/48 channels per Cube/RACKtangle
- MIL-1553: up to 14/24 redundant ports per Cube/RACKtangle

Typical Applications:

- Embedded Controller
- Hardware-in-the-loop controller
- Unmanned vehicle controller
- Wind energy and turbine controller
- Smart, Flexible data loggers
- Slaved controller with fail-safe local control and/or shut-down if communication is lost
- HVAC/ Environmental controller
- Modern replacement for obsolete VME systems
- Solar Energy system controller
- Machine Health Monitor
- DUT simulator
- In-vehicle test systems
- Avionics simulator
- Single and multiple PID loop controller
- Rugged and remote DAQ

System Block Diagram:

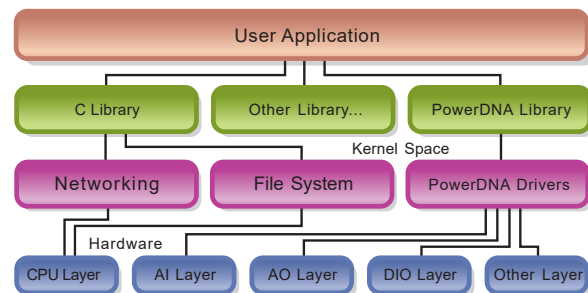

PLEASE SEE ORDERING GUIDE ON THE FOLLOWING PAGE

Ordering Guide: (All chassis include: Universal AC power supply, Serial and Ethernet cables and pre-installed Linux OS.)

	Chassis Configuration
300 ^{1,2}	100Base-T Linux-based, Programmable Automation Controller with 3 available I/O slots
600 ^{1,2}	100Base-T Linux-based, Programmable Automation Controller with 6 available I/O slots
700 ¹	100Base-T Linux-based, Programmable Automation Controller with 7 available I/O slots
100-1G	Gigabit Ethernet, Programmable Automation Controller with 1 available I/O slots (a.k.a. UEINET-PAC)
300-1G	Gigabit Ethernet, Programmable Automation Controller with 3 available I/O slots
600-1G	Gigabit Ethernet, Programmable Automation Controller with 6 available I/O slots
700-1G	Gigabit Ethernet, Programmable Automation Controller with 7 available I/O slots
600R	Gigabit Ethernet, Programmable Automation Controller, RACK tangle with 6 available I/O slots
1200R	Gigabit Ethernet, Programmable Automation Controller, RACK tangle with 12 available I/O slots
400F-AC	1U Flat RACK, rackmountable 4 slot chassis with Gigabit Ethernet and 100-240 VAC AC power
400F-DC	1U Flat RACK, rackmountable 4 slot chassis with Gigabit Ethernet and 9-36 VDC power
400-MIL	Military style, 4 slot Cube with GigE Ethernet ports and 38999 connectivity
600-MIL	Military style, 6 slot Cube with GigE Ethernet ports and 38999 connectivity
1200-MIL	Military style, 12 slot RACK tangle with GigE Ethernet ports and 38999 connectivity

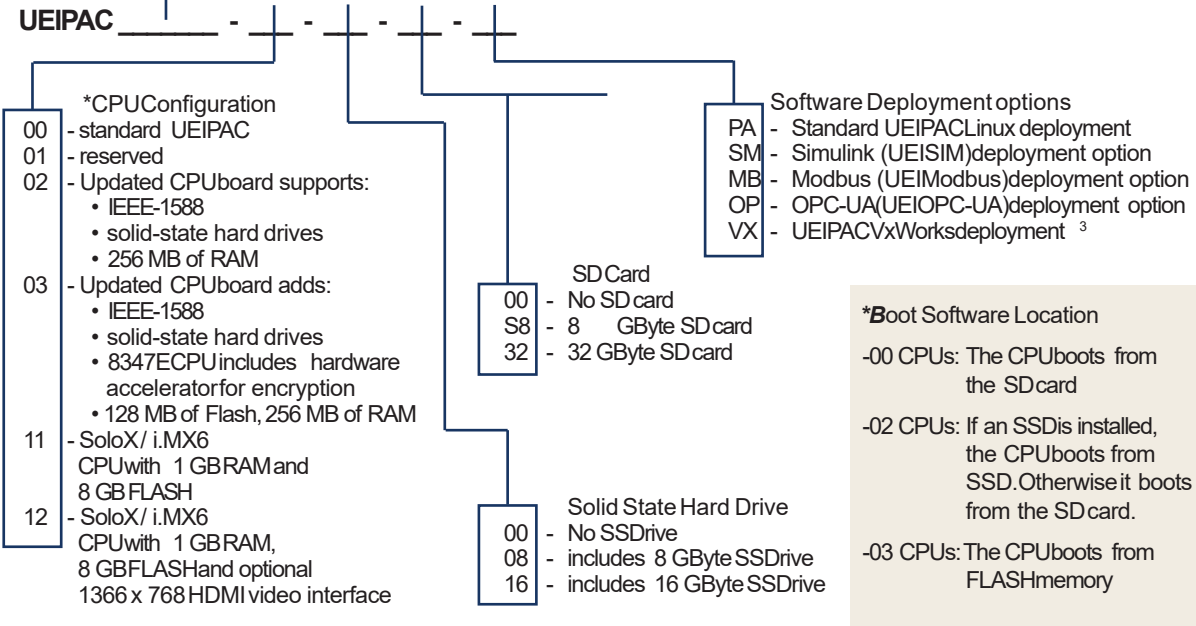

Software including SDK and Board Support Packages (Only one toolkit is required, regardless of the number of UEIPACs deployed)	
Part Number	Description
UEIPACVxWBSP(Software Only)	VxWorks Board Support Package (BSP) allows you to program your UEIPAC applications in VxWorks
UEIPAC-LinuxTK(Software Only)	UEIPAC Linux Programmer's Toolkit