

FABS-107P/R/G(H)

7" Flat Front Panel IP66 Stainless Chassis Display



Features

- Stainless steel front bezel display
- Flat front panel touch screen
- IP66/IP69K compliant front bezel
- VGA/DP/DVI/HDMI input
- OSD on the rear side
- System power LED light
- High brightness LCD for option
- Wide range DC 9~36V power input



Specifications

I/O Port	
VGA	1 x VGA
DVI	1 x DVI-D (share with HDMI)
DP	1 x DP
HDMI	1 x HDMI (share with DVI-D)
Audio	1 x Audio line-in phone jack
OSD Control Membrane	OSD at rear side On board controller, extendable key pad from connector
Power	1 x 3-pin terminal block for DC 9~36V power input
Others	1 x USB type B for touch control Optional I/O: 1 x Speaker

Display	Standard	High Brightness Optional
Display Type	7" TFT-LCD	7" TFT-LCD
Max. Resolution	800 x 480	800 x 480
Max. Color	262K	262K
Luminance (cd/m ²)	350	1000
View Angle	160(H) / 160(V)	160(H) / 160(V)
Contrast	1000:1	1000:1
Backlight Lifetime	30,000 hrs	30,000 hrs

Touch Screen	
Type	Projected Capacitive Touch (for P model) Resistive Touch (for R model) Glass (for G model)
Interface	USB
Light Transmission(%)	Resistive Touch: over 80% Projected Capacitive Touch: over 90%

Power	
Power Input	DC 9~36V
Power Consumption	FABS-107P: 3.7W

Mechanical	
Construction	304 Stainless steel front bezel (Default) 316L Stainless steel front bezel (Optional) Aluminum die-casting back cover
Mounting	Panel mount, VESA mount 75 x 75
IP Rating	IP66/IP69K compliant front bezel
Dimensions (WxHxD)	217 x 163 x 40 mm
Net Weight	1.4 kg

Dimensions

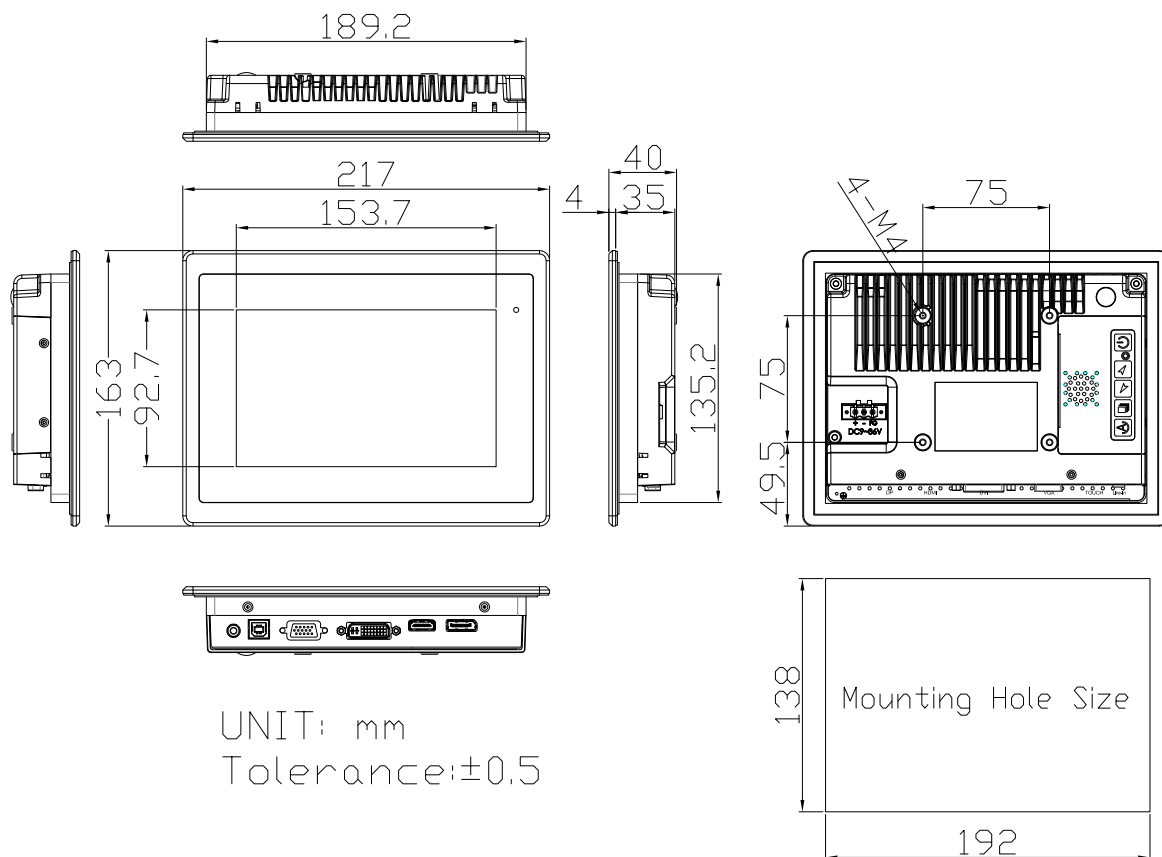

Environmental

Operating Temperature	0~50°C / -20~60°C (option)
Storage Temperature	-30~70°C
Humidity	10 to 95% @ 40°C, Non-condensing
Certificate	R/P/G/RH/PH/GH Model: CE/FCC Class A P/G Model is compliance with EN 1672-2 (option)
Vibration	1G/5~500Hz (Random) / Operation
Shock	15G peak acceleration (11 msec. duration) / Operation

V 1.4